



High Performance Chains



# STENTER CHAINS

*“For a Superior Stretch”*

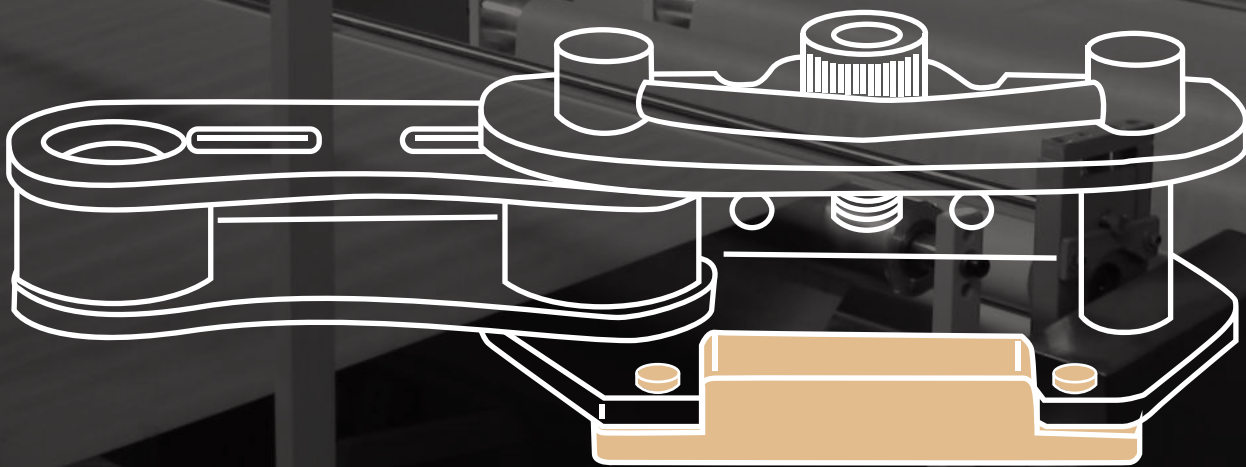

# STENTER CHAINS

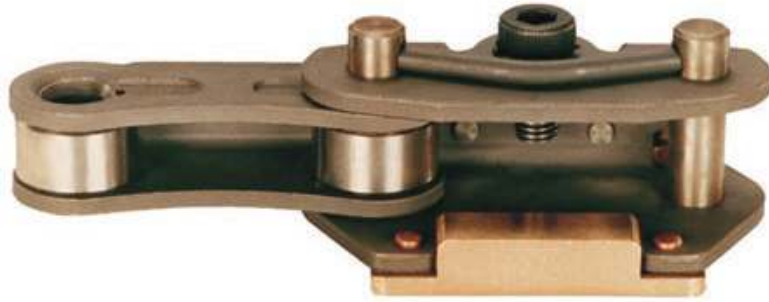

Specially designed chain with sintered liners ensures highest possible stretch, high operational speed with minimum/optimum energy consumptions.

TIDC Chains are suitable for



Artos Stenter machines



Harish Stenter machines

Chains are interchangeable to existing chains used in the Machine. However it is advisable to replace the entire chains upon elongation for better performance of chains and system.

Chains can be used from single chamber to 7 Chamber Machines

Chains are specially designed for superior performance at speed of 100 - 130 MPM



Chain links made of superior grade steel with higher tensile strength

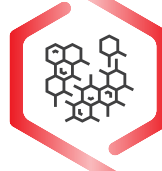

Sintered bronze liners



Hardened Pins and Bushes for improved wear resistance

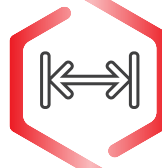

Closer pitch control for maintaining uniform chain width

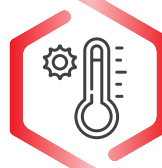

Suitable for operating at higher temperatures – up to 250 degrees celcius

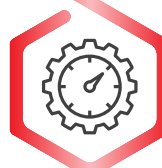

Superior wear life at higher operating speeds

