

ROLLER CHAIN COUPLINGS

Transmitting Relatively Higher Torque

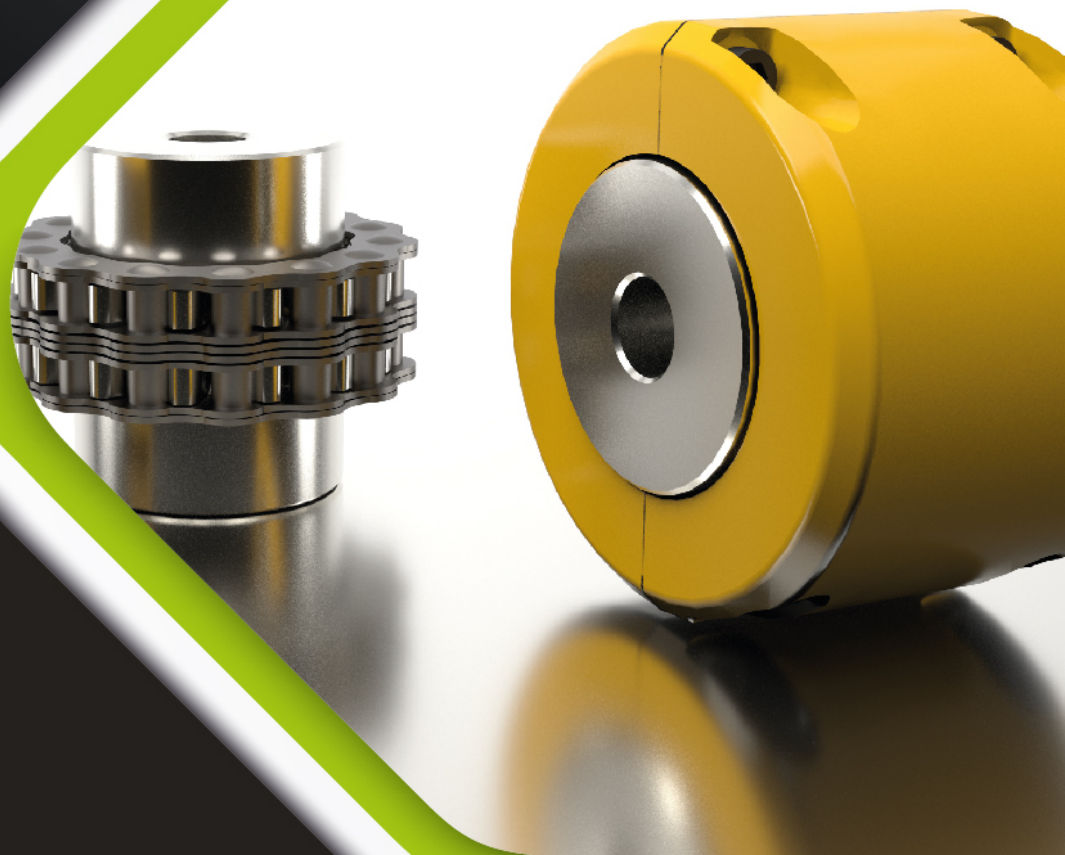

Outstanding
Durability



Easy Coupling
& Decoupling



Absorption of
Large Misalignment



Roller Chain Couplings are compact, long lasting flexible couplings, capable of transmitting relatively high torques with minimum of space consumption. Consequently, they provide a most economical means of positive transmission of power from one shaft to another.

The simple design and construction of these couplings make them extremely easy to install and disconnect, providing additional economy of operation.



Outstanding Durability

The coupling provides outstanding durability with the torque on the coupling, shared with the surface hardened teeth of the sprockets and the powerful roller chain that engages with the teeth.



Easy Coupling & Decoupling

Both shafts can be easily coupled or decoupled with a single joint pin inserted into or extracted from the roller chains.



Absorption of Large Misalignment

The clearances between the chain and sprockets and between chain components absorb the great positional misalignment of both shafts.

Body Construction

The body consists of two dedicated sprockets with hardened teeth and two-strand roller chains. The sprockets are coupled when the chains are wound around the sprockets, and decoupled with the chains removed; therefore, transmission power can be coupled or separated without moving the transmission system.

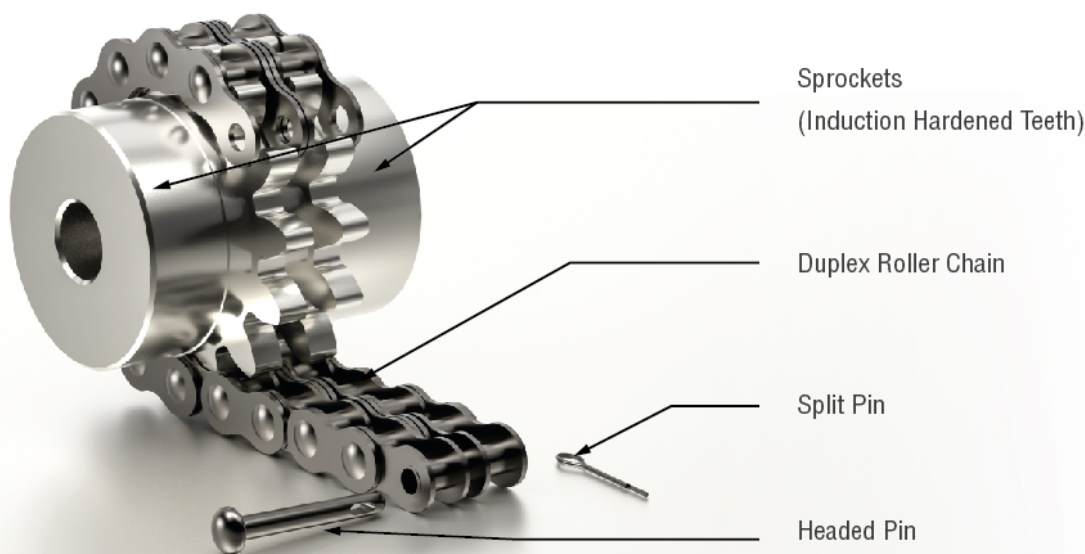

ROLLER CHAIN COUPLING MODELS

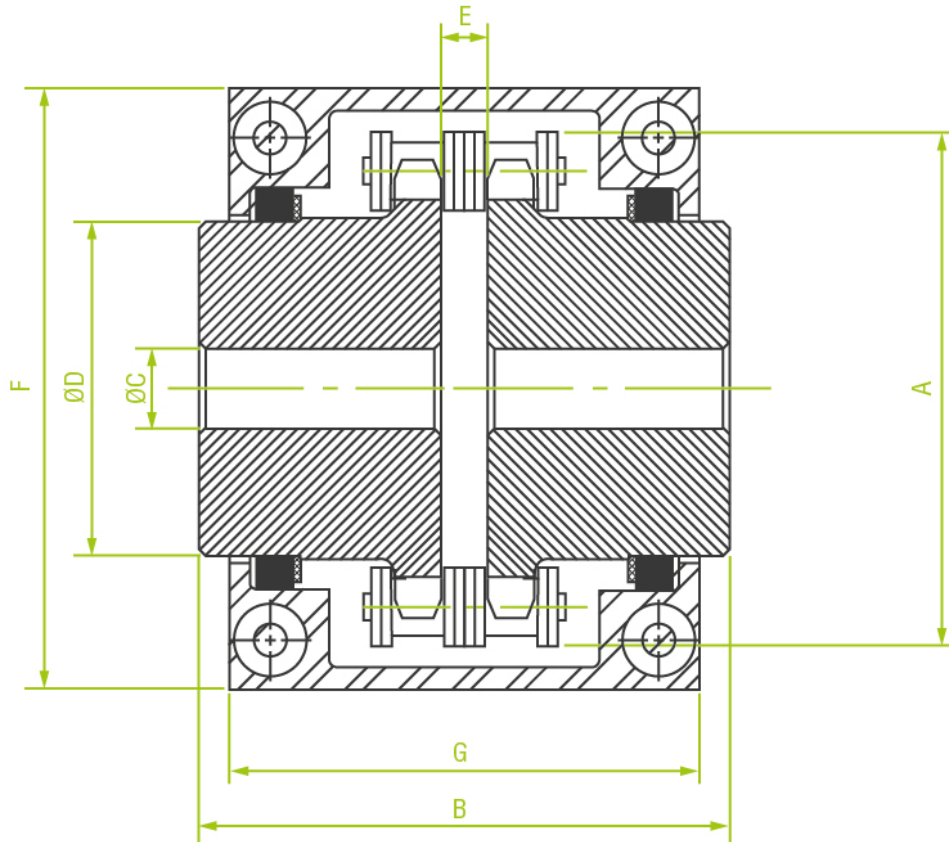

All dimensions are in Millimeters

Chain Coupling Model No.	JIS Code	Chain in use		Chain Pitch	Coupling Dimensions							Cover Dimensions # Material: Plastic / Aluminium		
		DIAMOND Chain Part No.	International Chain Ref. No.		Bore Diameter (ØC)		A	B	ØD	E	Weight (in kg)	F	G	#Weight (in kg)
					Min.	Max.								
D06102RCP12-01	3812	D06102	06B-2	09.525	10	16	45	65	27	5	0.3	69	59	0.2
D08302RCP12-01	4012	D08302	08B-2	12.700	10	22	60	79	35	7	0.8	75	68	0.2
D08302RCP16-01	4016	D08302	08B-2	12.700	12	32	77	79	50	7	1.6	90	70	0.4
D10102RCP16-01	5016	D10102	10B-2	15.875	16	42	96	96	61	8	2.6	114	86	0.6
D10102RCP18-01	5018	D10102	10B-2	15.875	16	48	106	98	71	8	3.5	123	90	0.8
D12002RCP18-01	6018	D12002	12B-2	19.050	20	60	126	121	88	9	6.5	149	93	1.2
D12002RCP22-01	6022	D12002	12B-2	19.050	20	76	150	121	110	9	10.0	173	110	1.6
D16002RCP18-01	8018	D16002	16B-2	25.400	25	80	170	150	115	16	14.5	195	135	2.3
D16002RCP22-01	8022	D16002	16B-2	25.400	25	95	201	150	140	16	20.0	222	135	2.4
D20002RCP20-01	10020	D20002	20B-2	31.750	40	110	231	200	157	18	33.5	258	174	3.4
D24002RCP18-01	12018	D24002	24B-2	38.100	50	119	254	260	169	24	51.0	292	218	5.9
D24002RCP22-01	12022	D24002	24B-2	38.100	50	150	301	260	208	24	76.0	340	212	7.3
D32002RCP18-01	16018	D32002	32B-2	50.800	50	160	341	360	220	30	121.0	385	250	14.0
D32002RCP22-01	16022	D32002	32B-2	50.800	50	199	410	360	280	30	210.0	-	-	-

- The range of bore diameters for the 4012 to 16022 confirms to JIS standards.
- The maximum bore diameter shows the permissible bore diameter for standard transmission with no impact or reverse rotation.
- Grease filled in space between the two sprockets, sprocket teeth and chain.
- Coupling Selection should be based on HP rating, Speed, torque and other environment conditions.

Cover weight will differ depending upon material – Plastic / Aluminium

SELECTION OF THE SIZE OF THE COUPLINGS



1

Decide service factor for the unit for which the chain coupling is to be fitted by considering the hours of service, type of power unit etc. from the following table

Service Classification	Driven Equipment		Source of Power		
	Kinds	Characteristics	Electric Motor or Steam Turbine	Steam Gasoline Engine 4 or more Cyl.	Diesel or Gas Engine
A	Centrifugal fans, blowers of pumps conveyor evenly loaded.	Even load - 8 hours/day service, non-reversing-low torque starting.	1.0	1.5	2.0
B	Compressor, conveyor, pulsating load machines, kilns and driers, speeds reducers, multi cylinder pumps, wood working machines, etc.	Uneven load - 8 hours/day service, moderate shock or torsional loads, non-reversing -This is the most common type of service	1.5	2.0	2.5
C	Presses, crushers, impact loads, oil well pumping equipment	Heavy shock load - 8 hours/day service, high peak torsional loads. Reversing under load, full load starting	2.0	2.5	3.0



8 to 16 hours/day service

use next step service factor.



16 to 24 hours/day service

use service factor two step higher loading.

2

Multiply horsepower of driver unit by the service factor. This is design horsepower.

3

Note the maximum rpm at which the unit will run and its shaft diameter.

4

From H.P. rating table select the coupling size which is rated equal to or slightly greater than design H.P. required at the rpm at which the coupling is to operate.

5

Also make sure that the diameter at the shaft is less than the maximum bore permissible on the coupling. If the coupling is not large enough to accommodate the shaft size, use the next coupling which can be bored to suit the shaft requirement.

HORSE POWER RATING TABLE

Unit (hp)

Chain Coupling Model No.	JIS Code	Bore Max. (in mm)	Revolution per minute (rpm)											
			1	5	10	25	50	100	200	300	400	500	600	800
D06102RCP12-01	3812	16	0.013	0.066	0.146	0.346	0.693	1.053	1.613	2.106	2.520	3.013	3.440	4.253
D08302RCP12-01	4012	22	0.026	0.146	0.293	0.773	1.533	2.306	3.506	4.613	5.533	6.613	7.560	9.346
D08302RCP16-01	4016	32	0.053	0.280	0.546	1.373	2.746	4.120	6.253	8.226	9.880	11.80	13.46	16.66
D10102RCP16-01	5016	42	0.106	0.520	1.040	2.600	5.213	7.813	11.89	15.60	18.80	22.40	25.60	31.73
D10102RCP18-01	5018	48	0.133	0.666	1.320	3.306	6.600	9.906	15.06	19.86	23.73	28.40	32.53	40.13
D12002RCP18-01	6018	60	0.240	1.240	2.493	6.226	12.44	18.66	28.40	37.33	44.80	53.46	61.20	75.73
D12002RCP22-01	6022	76	0.333	1.666	3.346	8.413	16.66	25.06	38.13	50.26	60.40	72.13	82.53	102.00
D16002RCP18-01	8018	80	0.546	2.760	5.520	13.73	27.60	41.33	62.93	82.80	99.33	118.66	134.66	168.00
D16002RCP22-01	8022	95	0.786	3.946	7.906	19.73	39.46	59.33	89.60	118.66	141.33	169.33	194.66	240.00
D20002RCP20-01	10020	110	1.240	6.213	12.44	31.06	62.13	93.33	141.33	166.66	224.00	266.66	305.33	377.33
D24002RCP18-01	12018	119	1.866	9.360	18.66	46.80	93.60	140.00	213.33	280.00	336.00	402.60	460.00	568.00
D24002RCP22-01	12022	150	2.413	12.09	24.13	60.40	120.93	181.33	274.66	362.66	434.66	520.00	594.66	734.66
D32002RCP18-01	16018	160	4.040	20.13	40.40	101.06	201.33	302.66	460.00	606.66	728.00	869.33	994.66	1229.30
D32002RCP22-01	16022	199	5.906	29.46	59.06	146.66	294.66	444.00	674.66	886.68	1065.30	1272.00	1453.30	1800.00

Unit (hp)

Chain Coupling Model No.	JIS Code	Bore Max. (in mm)	Revolution per minute (rpm)											
			1000	1200	1500	1800	2000	2500	3000	3600	4000	4800	5200	6000
D06102RCP12-01	3812	16	5.173	5.880	7.133	8.333	8.973	10.82	12.58	14.66	16.00	18.86	19.73	22.26
D08302RCP12-01	4012	22	11.38	12.90	15.46	18.26	19.73	23.56	27.60	32.13	35.06	41.06		
D08302RCP16-01	4016	32	20.40	23.06	28.00	32.53	35.06	42.53	49.33	57.33	62.53	73.20		
D10102RCP16-01	5016	42	38.53	43.86	53.20	61.86	66.66	80.80	93.86	108.80				
D10102RCP18-01	5018	48	48.80	55.46	66.733	78.40	84.53	102.40	118.13					
D12002RCP18-01	6018	60	92.13	104.53	126.93	148.00	160.00	193.33						
D12002RCP22-01	6022	76	124.13	140.00	170.66	198.66	214.66	260.00						
D16002RCP18-01	8018	80	204.00	232.00	281.33	328.00	353.33							
D16002RCP22-01	8022	95	292.00	332.00	402.60	469.33	505.33							
D20002RCP20-01	10020	110	460.00	522.66	634.66	738.66								
D24002RCP18-01	12018	119	692.00	786.86	954.66									
D24002RCP22-01	12022	150	894.66	1016.00										
D32002RCP18-01	16018	160	1496.00											
D32002RCP22-01	16022	199	2186.60											

LUBRICATION

Couplings operating without covers under fairly clean conditions will give satisfactory service provided they are periodically (weekly) brushed thoroughly with ball bearing grease of medium consistency. Couplings operating with covers should be kept filled with a good quality ball bearing grease of soft or medium consistency.

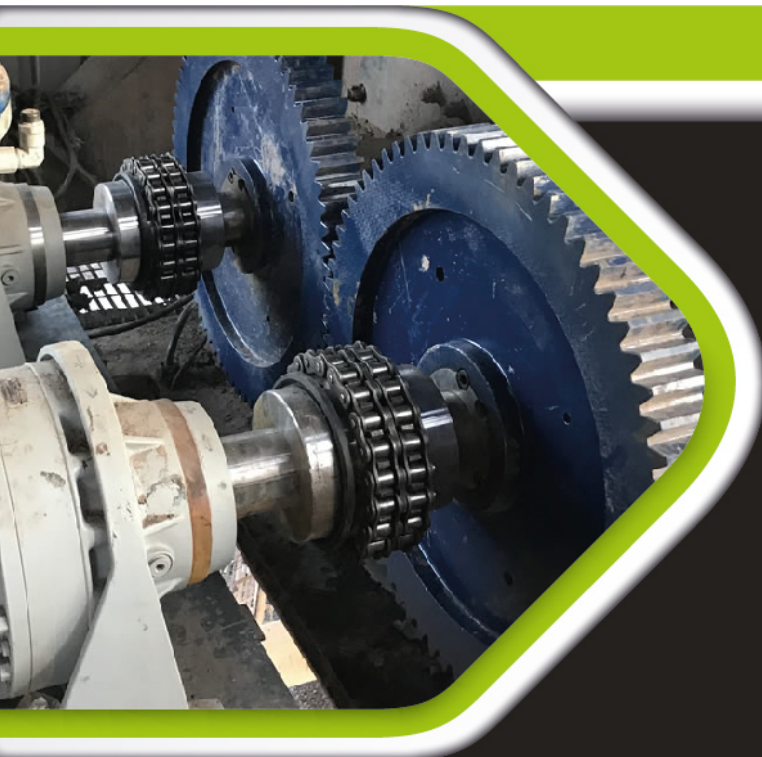

PRECI 
— PRECISION REDEFINED

TIDC INDIA

Post Bag No: 11, CTH Road,
Ambattur, Chennai - 600 053.

☎ +91 - 44 - 42235509

✉ industrialchains@tii.murugappa.com

🌐 www.tidcindia.in