



Aiding motion in every industry



CHAINS FOR FERTILIZER INDUSTRY



**ENGINEERING
CLASS CHAINS**

TIDC INDIA

**THE COMPLETE
CHAIN COMPANY**



TIDC engineers use Auto CAD, Solid works and Finite Element Analysis for cutting edge solution in the design of the chains, and the manufacturing technology process is plotted out with equal care. The resulting products are comprehensively tested at our labs, before they eventually find their way to a Diamond Customer.

A Trusted Brand in Conveyor Chains

The company has enormous strengths in conveyor chains, making chains for various applications in different Industries.

TIDC Means chains with more strength

Strict and complete adherence to consistent quality and regular technology up gradation have ensured TIDC chains exceed all laid down parameters

- High strength – higher breaking load. TIDC chains are tested for higher breaking load values than the international standard, endowing them with extra strength you can count on.
- Tough construction – to withstand shock load conditions common in rugged applications. TIDC has the edge in raw materials, design as well as manufacturing processes that enables us to build chains that are more rugged.
- High tensile strength – certain applications call for chains with better tensile strength, and TIDC works this feature into their products at every stage of production.
- Attachment – regular and made to order attachments are offered based on client needs.

Quality, the TIES THAT Bind Everything

Total Quality Management is a governing principle at TIDC India and we have our own quality system in place called 'TIES' (T.I. Excellence System)

TIDC India – The complete chain Company

Diamond India chains are designed and manufactured by TIDC India, a part of the prestigious Murugappa Group, one of the most trusted and respected business groups in India. A Group that is renowned for its belief in ethical business practices, innovative processes and people development.

Over six decades, TIDC has built chains for virtually every sector of industry. From tiller chains, agricultural chains, leaf chains and conveyor chains to industrial power drive chains, motorcycle drive chains and engine mechanism chains, our expertise is moving men and material across every sphere of life. And today, we possess the capability to meet any requirements in chains, anywhere in the world.

Our Strength : R & D

At TIDC, we owe our success to continuous improvement. Innovating products that suit customer needs better, makes us to constantly improve. Every choice with regards to size, material or method is in direct response to the needs of application engineers in the industries we serve.



encompassing all aspects of functioning. Beginning with the design phase, purchase and inspection of raw materials, vendor management, work instructions and going on to cover all processes in manufacturing, packing and inspections before delivery.

TIES also provides for stringent procedures when it comes to traceability of products and reviews of customer feedback.

The TIES system functions by nurturing quality as an integral part in the entire value chain, and is now completely internalized by the company.

The Best Certificates are Those that comes from our clients

We are one of the world's few companies to be certified for API 7F specifications by the American petroleum Institute for oil field chains.

Our manufacturing processes right from product design to testing of finished chains conform to ISO 9000:2000 standards and are certified by RWTUV of Germany. Our Motorcycle Engine Mechanism Chain and Fine Blanking Divisions are certified to TS 16949 standards by underwriters Laboratories, USA.

But what gives us the most pride is, the approval and repeat orders that comes to us from our clients all over India & across the world.

Product Leadership

Customers turn to TIDC for products that are designed for high performance, expanded equipment life and enhanced productivity. If you need chains that operate reliably in challenging environments, TIDC is the right source.

We apply our decades of research, engineering, manufacturing and service knowhow for every application. Because of our own performance

advantages, large OEMs turn to TIDC for products and support. This same OEM quality is offered to our after market products. That is why you will find our chains used in every tough applications.

TIDC engineers are committed to understanding your process and solve unique application problems. We work with you to optimize chain performance in the above stated products.

We use this spirit of collaboration to develop customized power transmission solutions.

Great Fatigue and Tensile Strength

The plates in each and every TIDC chain undergo piercing operation to extremely accurate specifications. Followed by Shaving or Drifting to increase bearing area, guaranteeing greater dynamic strength and fatigue life.

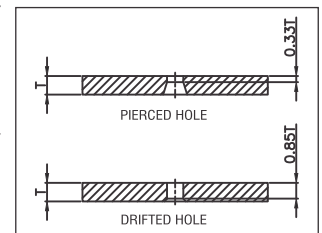

Longer Wear Life

Roundness of the bushes and heat treatment of pins and bushes impact wear life. At TIDC bushes and pins are produced using numerically controlled machines which produces them with greater accuracy.

Heat Treatment



Heat treatment is our core competency at TIDC. Our team has rich experience in heat treatment to maximize strength and life in every chain elements: pins, bushing, rollers and link plates. We deploy our specialist skills in continuous hardening operations for martensitic heat treatment. Under a completely automated atmosphere we work with high, medium and low carbon steels, alloy steels, austenitic and martensitic stainless steels etc. Other treatments we offer based on customer specifications are:

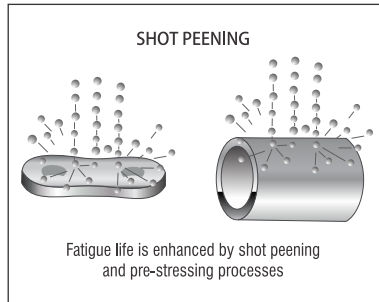

Shot peening for Maximum Load Capability/Shot Peening

Critical applications call for chains with high working load capability, plates and rollers are shot peened after heat treatment thereby increasing fatigue life. It is done by constantly bombarding the component with hard metal pellets at high speeds.

Corrosion Resistance

TIDC offers plating options, for corrosion resistance and enhanced product life – chromised pins have been proven to improve performance dramatically.



Testing

TIDC has immense capabilities for testing to validate the quality of their products. Every batch goes through stringent testing protocol, which covers fatigue tests, corrosion tests and much more. TIDC conveyor chains are built to exceed international standards, and this performance level is meticulously tested before the products reach you.



BUCKET ELEVATOR CHAINS

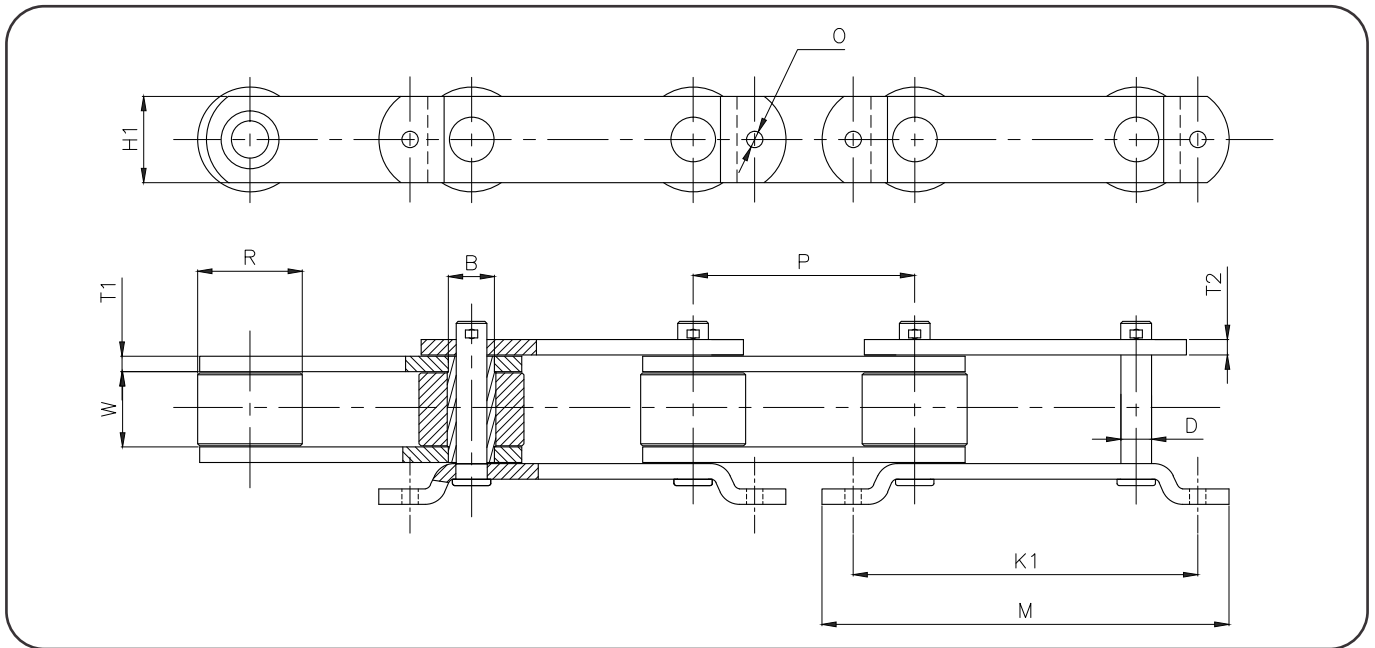

TIDC MODEL NO	Pitch (P)	WIP (W)	Plate Height (H1)	I/P Thk. (T1)	O/P Thk. (T2)	Roller Diameter (R)	Pin Diameter (D)	Minimum Breaking Load, Kgf	Attachment Type	Att. hole Pitch (K1)	Att. Hole Diameter (O)	Overall Width (M)
SP 2305	228.60	65.50	63.50	12.70	12.70	44.45	25.00	58000	G5	355.60	17.50	420.00
S 22860 04 BE G5 1A	228.60	81.55	100.00	16.00	16.00	114.30	38.10	110000	G5	388.00	20.50	450.00
S 22860 19 BE G5 1A	228.60	66.68	63.50	12.70	12.70	76.20	25.40	29500	G5	355.60	15.88	419.10
S 22860 28 BE G5 1A	228.60	77.70	88.90	16.00	16.00	108.00	31.75	90000	G5	355.60	16.80	420.00
S 22860 29 BE G5 1A	228.60	66.68	63.50	12.70	12.70	76.20	25.40	58000	G5	356.50	17.00	419.10

BUCKET ELEVATOR CHAINS

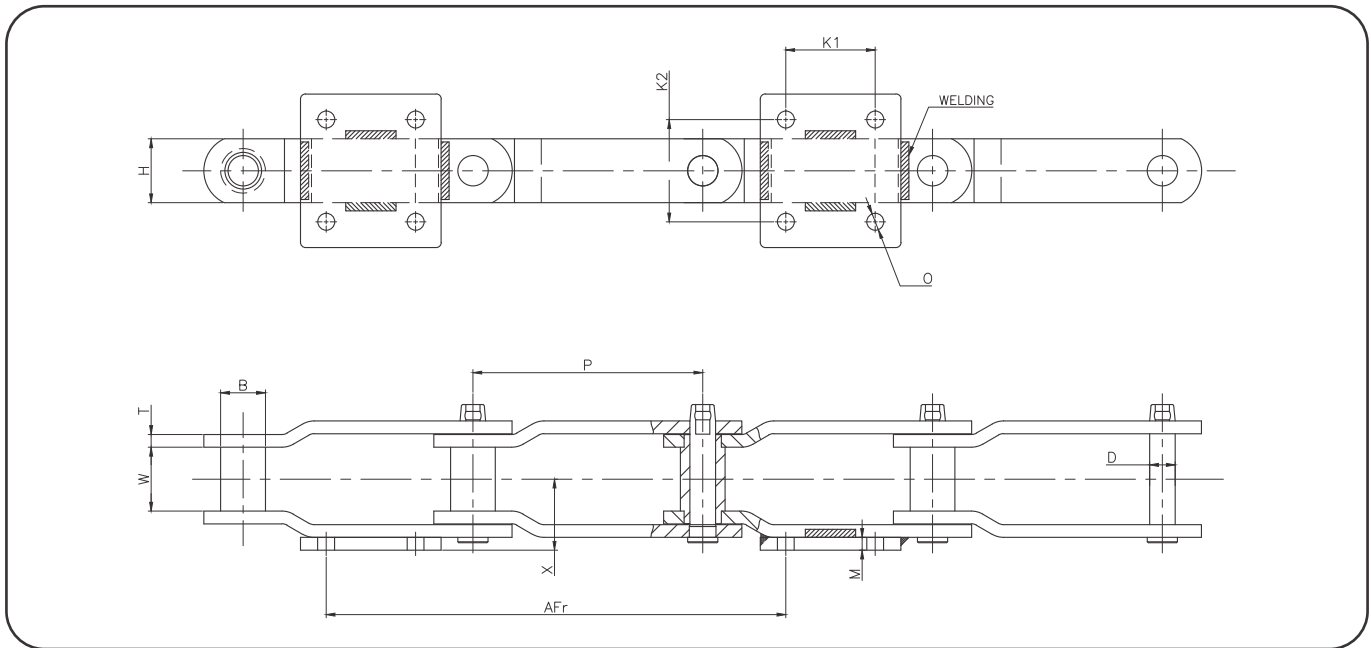

TIDC DRG. NO.	Pitch (P)	WIP (W)	Plate Height (H)	Plate Thk. (T1)	Att Plate Thk. (M)	Bush Diameter (B)	Pin Diameter (D)	Minimum Breaking Load, Kgs	Dist bet Attachments (AFr)	Att hole Pitch 1 (K1)	Att hole Pitch 2 (K2)	Att hole Diameter (O)	Att height from Chain center (X)
SP 6859	228.60	63.50	63.50	12.70	12.70	44.45	25.40	58600	457.20	88.90	101.60	16.70	70.60
SP 2281	228.60	57.15	76.20	16.00	16.00	50.80	34.93	74500	457.20	88.90	101.60	16.70	78.20
SP 2339	228.60	57.70	80.00	16.00	16.00	50.00	34.90	84250	457.20	88.90	115.00	17.00	79.00
SP 2369	228.60	76.20	90.00	16.00	20.00	60.35	38.10	100000	457.20	89.00	140.00	16.70	92.00
SP 2180	228.60	76.20	90.00	16.00	20.00	60.35	38.10	117000	457.20	89.00	140.00	16.70	92.00
S 22860 02 BE SG9 2L	228.60	88.90	100.00	16.00	20.00	63.50	38.10	120000	457.20	89.00	152.40	17.50	98.00
S 22860 12 BE G9 2L	228.60	76.20	70.00	12.70	12.70	44.45	25.40	68000	457.20	88.90	120.65	16.70	78.00

RIVETLESS FORGED LINK CHAINS

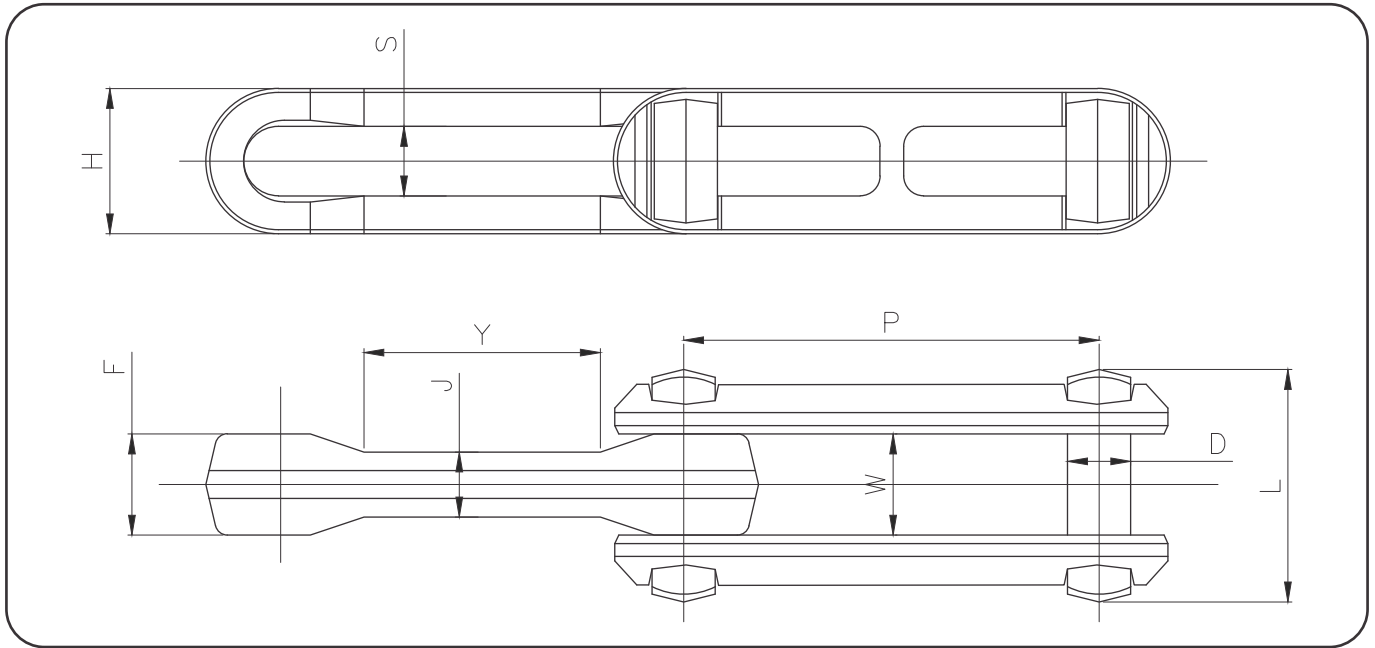

TDC DRG. NO.	Pitch (P)	WIP (W)	Link Height (H)	Link Thickness 1 (F)	Link Thickness 2 (J)	Inner Link Straight Portion (Y)	Width (S)	Pin Diameter (D)	Pin Length (L)	Minimum Breaking Load, Kgf
S 07660 01 X348	76.60	20.10	28.00	18.80	13.00		13.50	12.40	44.00	10000
S 10240 01 X458	102.40	27.20	36.50	25.40	16.30		17.50	15.88	58.50	19000
S 15320 01 X678	153.20	34.30	51.60	32.50	21.10		24.10	22.10	77.00	32400
SP 2111	153.67	40.00	65.90	39.20	25.40	88.90	29.80	28.60	96.80	71000
SP 1954	229.40	51.00	78.00	50.00	33.50	152.00	37.20	35.00	121.00	100000
S 22860 01 FG RLS	228.60	51.00	78.00	50.00	33.50	152.00	37.20	35.00	121.00	100000
S 22938 01 FG RLS	229.38	63.00	96.80	61.91	41.27		49.21	44.45	148.00	17000

ATTACHMENT CHAINS

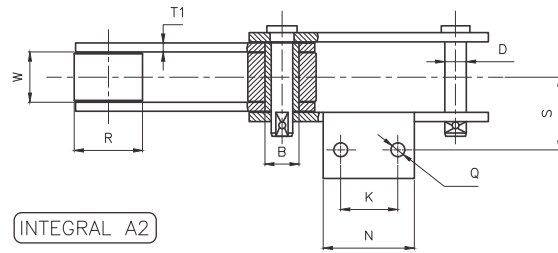
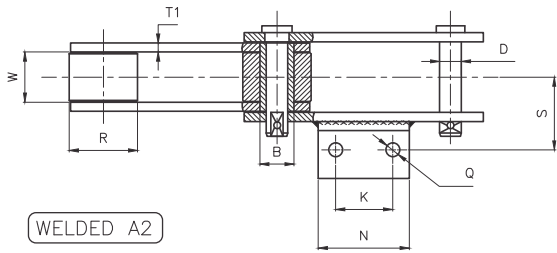
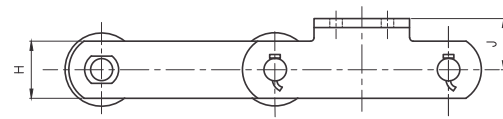
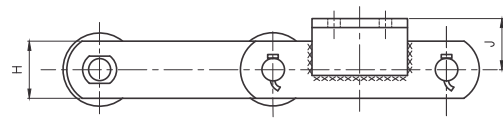

WELDED A2

INTEGRAL A2

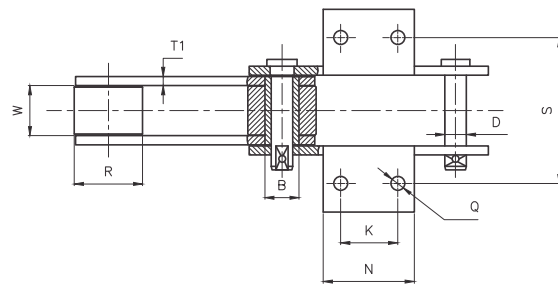
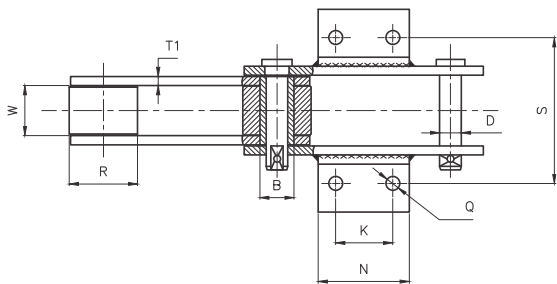
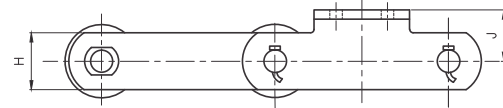
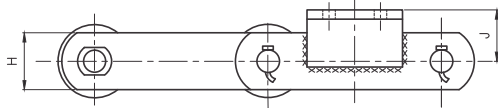

WELDED K2

INTEGRAL K2

Att. Type	TDC DRG. NO.	Pitch (P)	WIP (W)	Plate Height (H)	I/P Thk. (T1)	O/P Thk. (T2)	Roller Diameter (R)	BUSH Diameter (B)	Pin Diameter (D)	Minimum Breaking Load, Kgs	Att. Height (J)	Chain Center to Att. hole center (S)	Att. hole Pitch (K)	Att. Hole Diameter (Q)	Att. Length (N)
Welded A2 type	S 10160 35 SC WA2 1L	101.60	30.00	30.00	4.00	4.00	42.00	-	10.00	8000	28.00	55.25	40.00	12.00	70.00
	S 10160 67 SC WA2 1L	101.60	20.00	40.00	5.00	5.00	50.00	-	12.50	15000	35.00	44.25	30.00	11.00	56.00
	S 15240 42 DC WA2 1L	152.40	48.00	75.00	16.00	16.00	90.00	-	25.27	75000	25.00	86.00	63.50	14.30	101.60
Welded K2 type	S 10160 52 BE WK2 2A	101.60	26.00	45.00	6.00	6.00	-	25.00	15.80	12000	32.00	90.00	38.00	11.00	65.00
	SP 2327	152.40	30.00	40.00	8.00	8.00	50.00	-	17.74	15000	40.00	120.00	50.00	12.00	88.00
	S 15240 55 BE WK2 1A	152.40	44.00	50.00	8.00	8.00	-	30.00	20.00	30000	45.00	128.00	50.00	12.00	80.00
	SP 1988	160.00	42.00	60.00	8.00	8.00	-	30.00	21.00	38000	55.00	140.00	65.00	18.00	120.00
	SP 1891	228.60	86.00	76.20	12.70	12.70	-	45.50	25.40	70000	44.45	203.20	152.40	20.00	203.20
Integral A2 type	S 10160 76 SC FR A2 1L	101.60	27.00	28.60	6.00	6.00	44.50	-	11.30	8000	28.00	50.00	40.00	12.00	70.00
	S 10160 49 SC FR A2 1L	101.60	32.00	40.00	10.00	10.00	57.00	-	18.00	30000	30.00	51.00	40.00	12.00	68.00
	S 22860 36 BE A2 1A	228.60	35.00	50.00	8.00	8.00	-	26.00	17.70	16500	38.00	92.00	80.00	17.00	142.00
Integral K2 type	SP 2338	101.60	54.00	40.00	10.00	10.00	-	25.40	15.00	18600	25.40	135.00	44.50	11.00	75.00
	SP 1906	152.40	76.20	63.50	12.70	12.70	-	44.45	25.40	59000	44.50	160.00	57.00	14.00	110.00
	SP 2289	152.40	76.20	63.50	12.70	12.70	-	44.45	25.40	45300	47.62	160.34	57.15	13.00	103.00

BUCKET ELEVATOR CHAINS

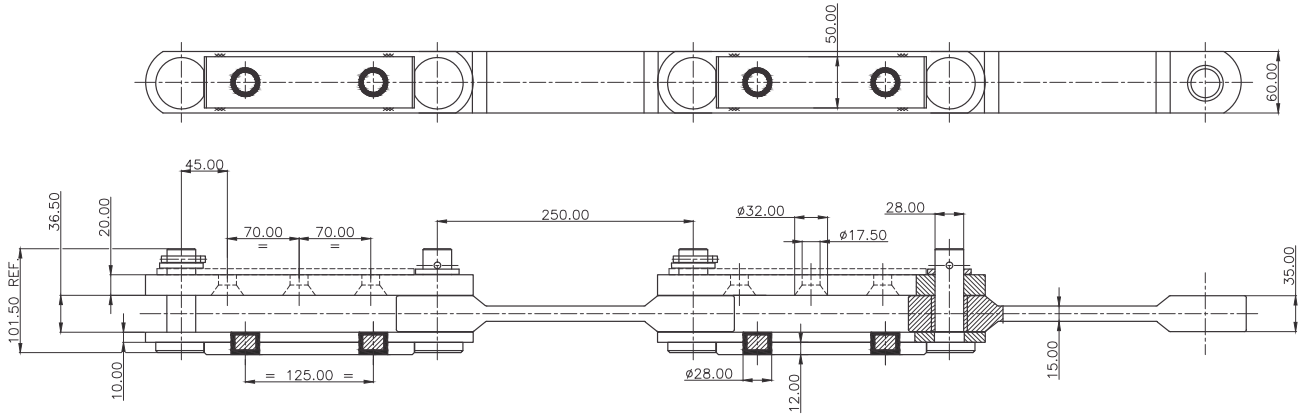

TIDC MODEL:S 25000 65 BE FG
MINIMUM BREAKING LOAD= 27,200 KGF

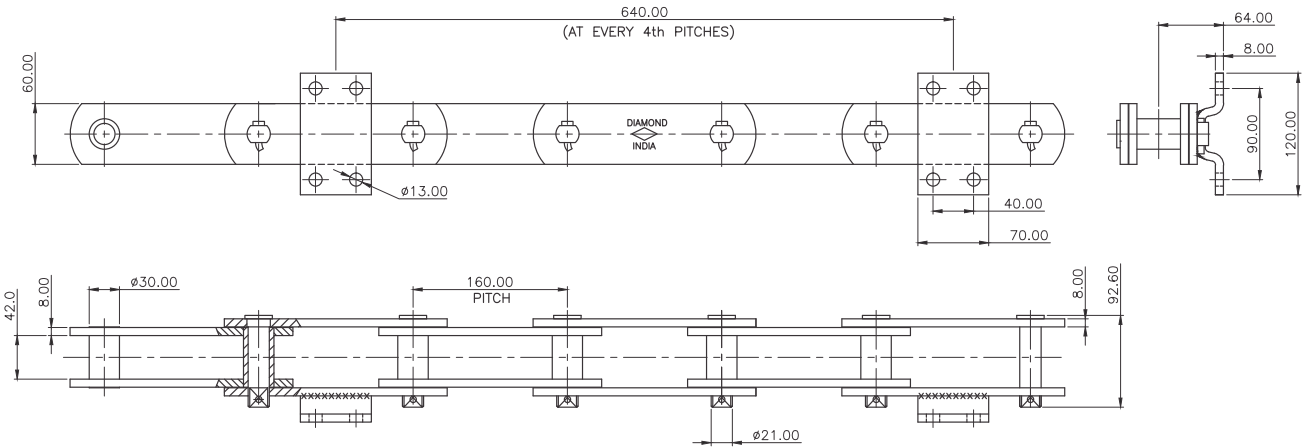

TIDC MODEL: SP 1989
MINIMUM TENSILE STRENGTH = 38,000 KGF

BUCKET ELEVATOR CHAINS

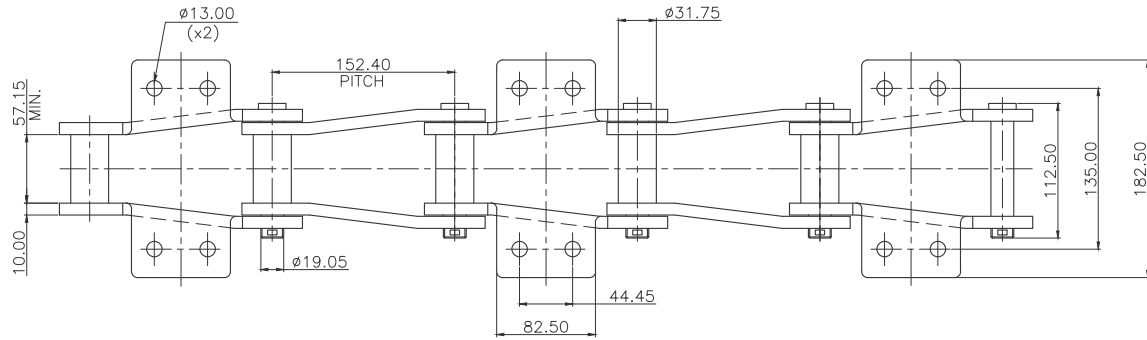
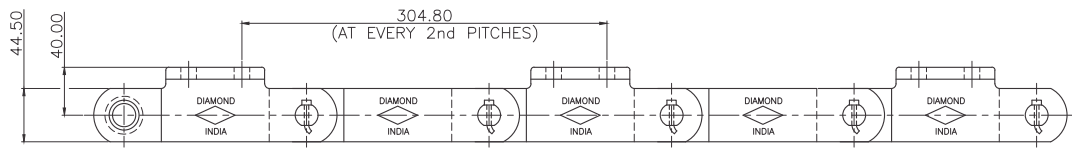

TIDC MODEL: SP 1850

MINIMUM TENSILE STRENGTH = 27,230 KGF.

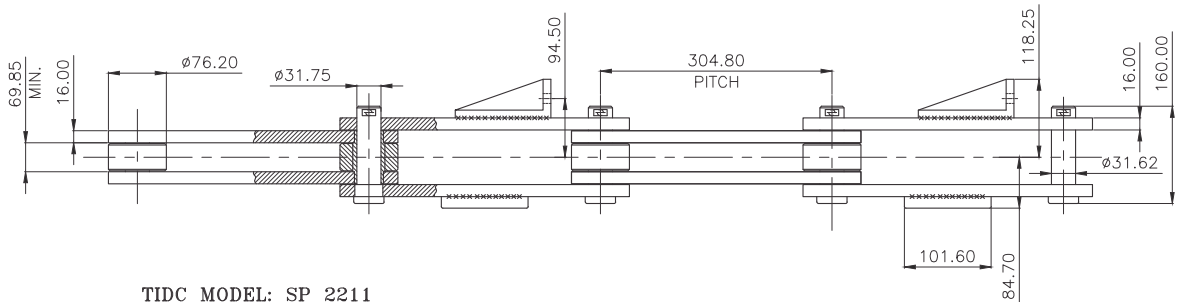
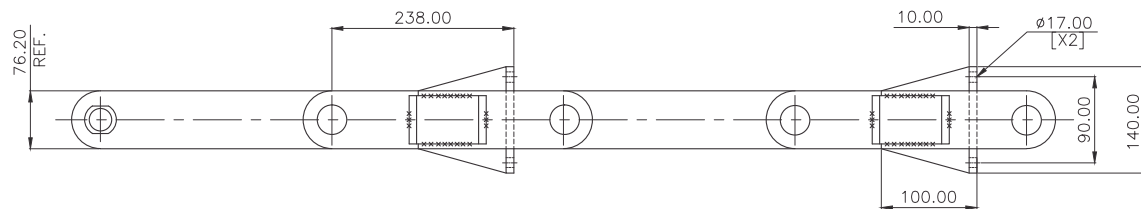

TIDC MODEL: SP 2211

MINIMUM BREAKING LOAD = 50,000 KGF.

BUCKET ELEVATOR CHAINS

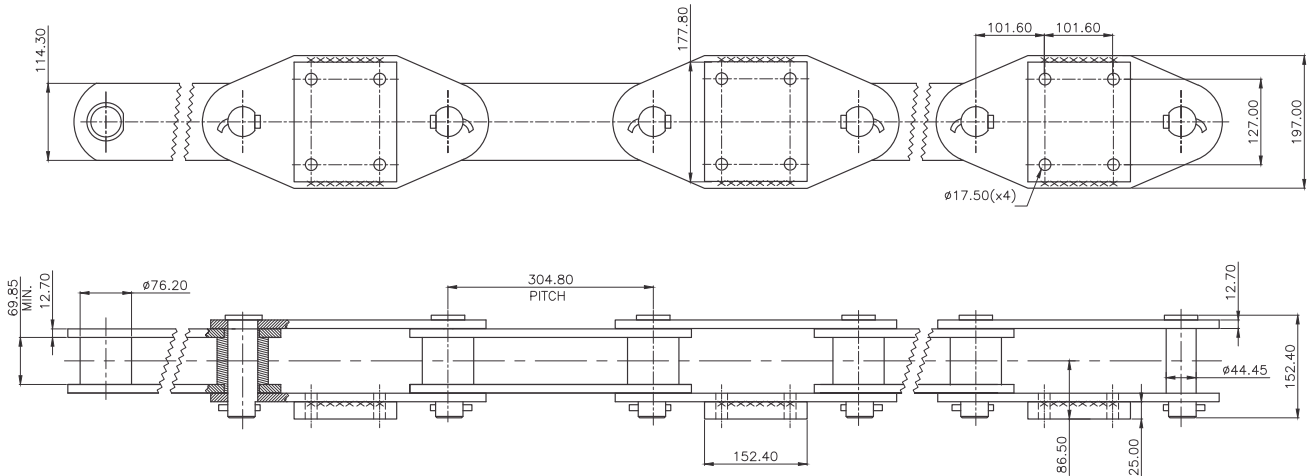

TIDC MODEL: SP 2295

MINIMUM TENSILE STRENGTH = 1,00,000 KGF

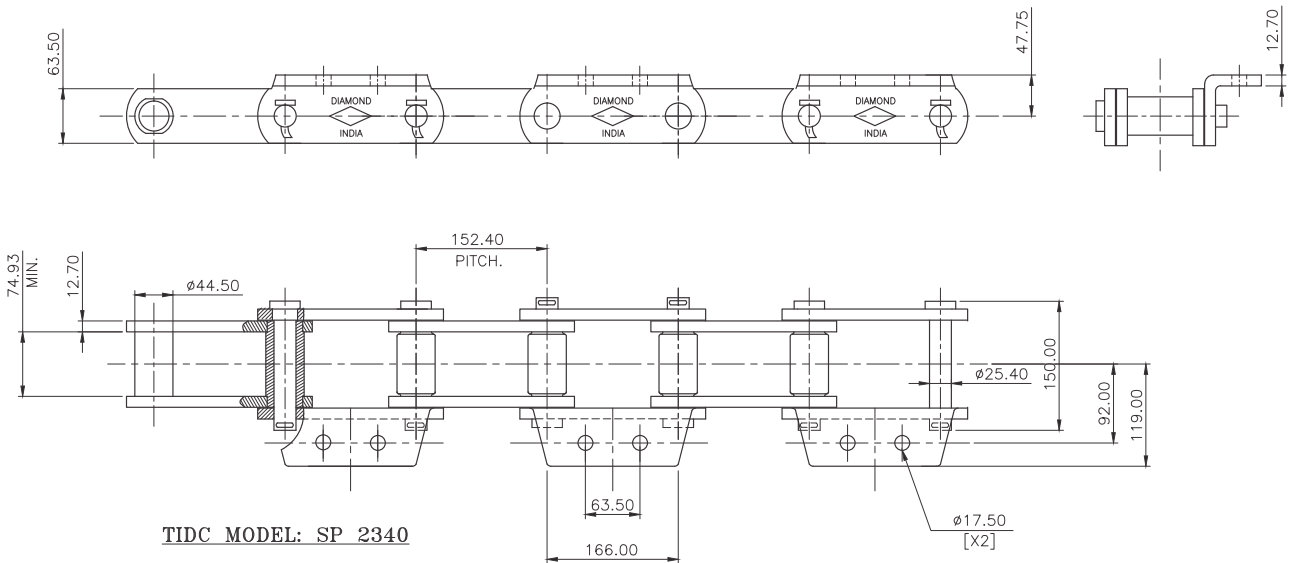

TIDC MODEL: SP 2340

MINIMUM BREAKING LOAD = 30,000 KGF

BUCKET ELEVATOR CHAIN

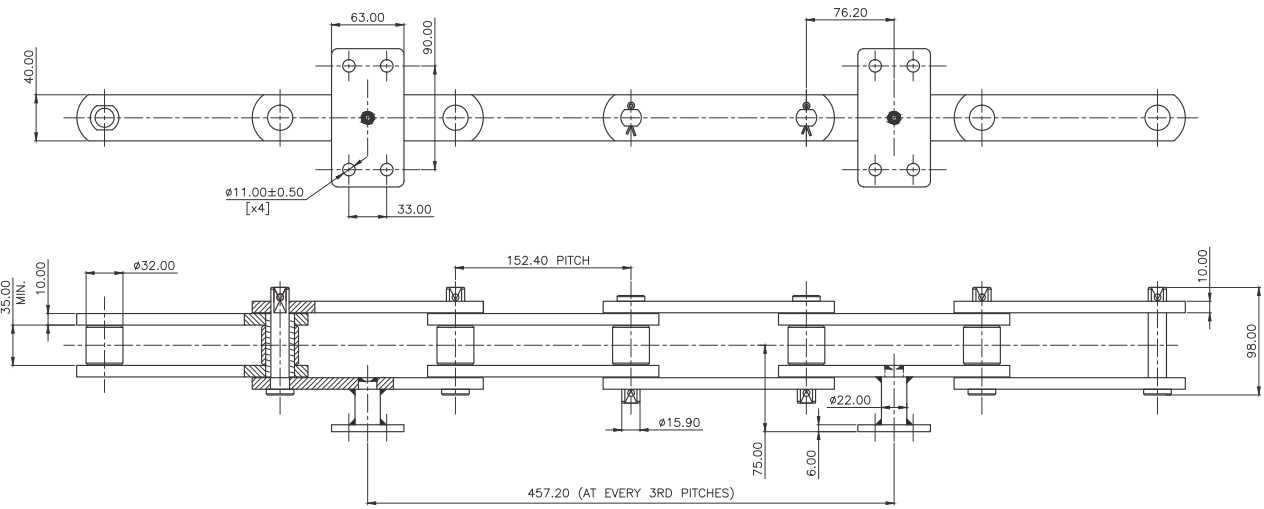

TDC MODEL: S 15240 48 BE G2 3L
 MINIMUM BREAKING LOAD= 20000 KGF

DRAG CHAIN

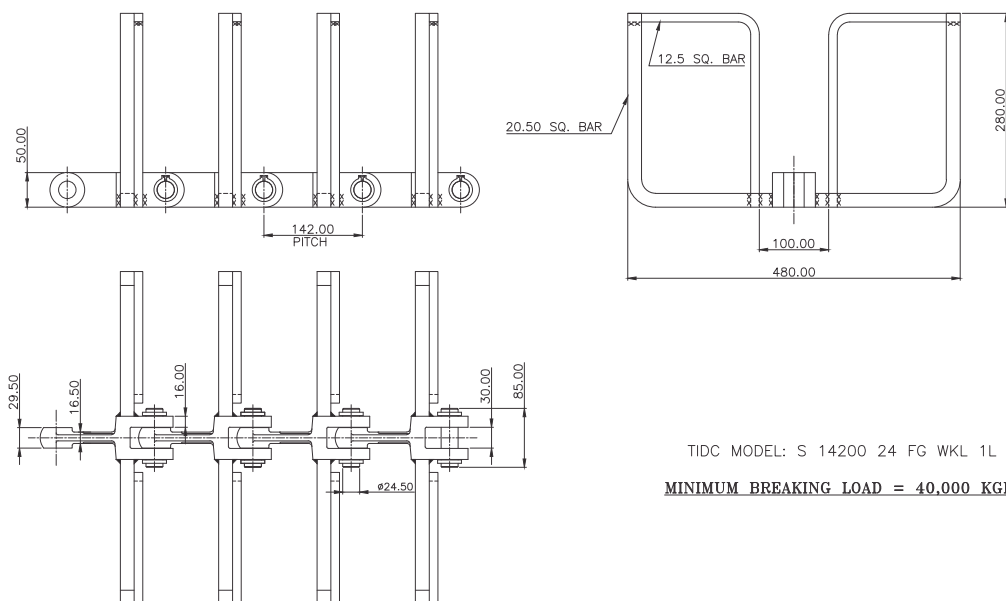

TDC MODEL: S 14200 24 FG WKL 1L
 MINIMUM BREAKING LOAD = 40,000 KGF

BUCKET ELEVATOR CHAIN

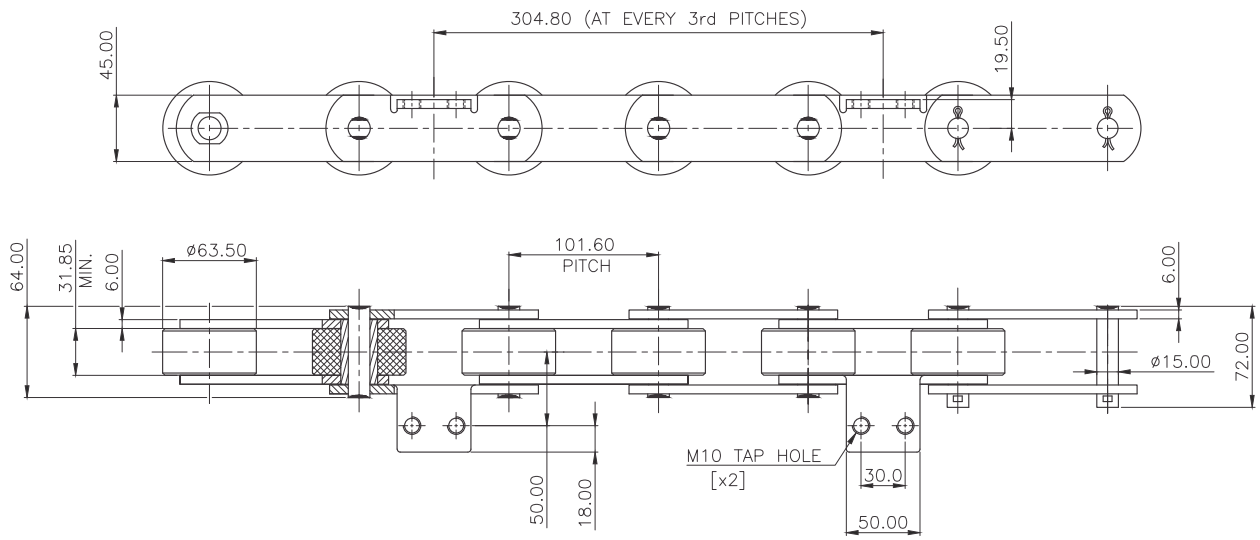

TIDC MODEL: S 10160 39 BE SS A2 3L

MINIMUM BREAKING LOAD = 10,000 KGF

STANDARD ROLLER CHAINS

EUROPEAN SERIES



ISO 606/BS 228/DIN 8187

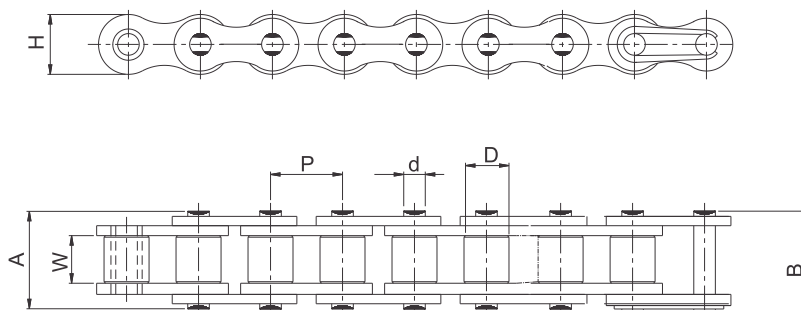

The European series of roller chains are designed for use in mechanical power transmission systems.

SINGLE STRAND

Intl. Ref No.	ROMBO Chain No.	Pitch (P)	Width between Inner Plates (W) (Min)	Roller Dia (D) (Max)	Bearing Pin Dia (D) (Max)	Plate Height (H) (Max)	Width over Bearing Pin (A) (Max)	Width over Joint Fasteners (B) Max	Projected bearing Area Sq.cm	Avg. Weight Per Meter (Kg)	Tensile Strength (KN) (Min)	Tensile Strength (KN) (Avg)	Spares Availability
04B-1	D04B 01	6.00	2.80	4.00	1.85	5.00	7.40	10.30	0.08	0.12	3.00	3.33	A,B,C,D
05B-1	D05B 01	8.00	3.00	5.00	2.31	7.10	8.60	11.70	0.11	0.18	5.00	5.90	A,B,C,D
06B-1*	D061 01	9.525	5.72	6.35	3.28	8.20	13.50	16.80	0.28	0.40	9.00	10.70	A,B,C,D
08B-1	D083 01	12.70	7.75	8.51	4.45	11.80	17.00	20.90	0.50	0.68	18.00	21.10	A,B,C,D
10B-1	D101 01	15.875	9.65	10.16	5.08	14.70	19.60	23.70	0.67	0.91	22.40	27.45	A,B,C,D
12B-1	D102 01	19.05	11.68	12.07	5.72	16.10	22.70	27.30	0.88	1.12	29.00	32.35	A,B,C,D
16B-1	D160 01	25.40	17.02	15.88	8.27	21.00	36.10	41.50	2.07	2.59	60.00	70.60	A,B,C,D
20B-1	D200 01	31.75	19.56	19.05	10.19	26.40	43.20	49.30	2.91	3.60	95.00	109.85	A,B,C,D
24B-1	D240 01	38.10	25.40	25.40	14.63	33.40	53.40	60.00	5.49	6.85	160.00	179.00	B,C,D
28B-1	D280 01	44.45	30.99	27.94	15.90	37.00	65.10	72.50	7.26	8.56	200.00	226.00	B,C,D
32B-1	D320 01	50.80	30.99	29.21	17.81	42.20	67.40	75.30	8.05	9.49	250.00	272.80	B,C,D
40B-1	D400 01	63.50	38.10	39.37	22.89	52.90	82.60	92.60	12.61	15.53	355.00	390.50	B,C,D
48B-1	D480 01	76.20	45.72	48.26	29.24	63.80	99.10	109.10	20.40	24.45	560.00	602.00	B,C,D

* Straight Side Plates

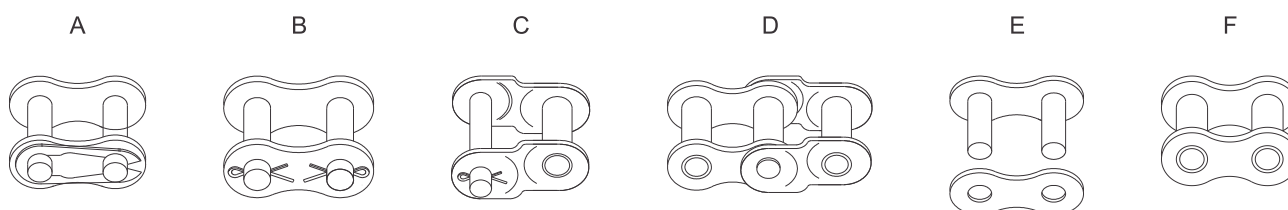

Note : Spares E & F are available for all models

STANDARD ROLLER CHAINS

EUROPEAN SERIES

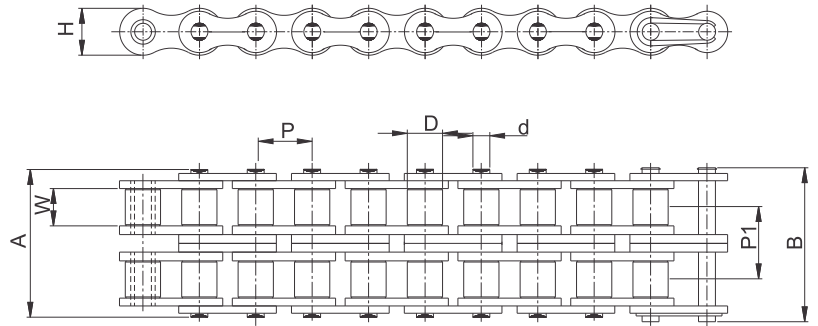

ISO 606/BS 228/DIN 8187

DOUBLE STRAND

Intl. Ref. No.	ROMBO Chain No.	Pitch (P)	Width between Inner Plates (W) (Min)	Roller Dia (D) (Max)	Bearing Pin Dia (d) (Max)	Plate Height (H) (Max)	Width Over Bearing Pin (A) (Max)	Width Over Joint Fasteners (B) (Max)	Transverse Pitch (P1)	Projected Bearing Area (Sq.cm)	Avg. Weight Per Metre (Kg)	Tensile Strength (KN) (Min)	Tensile Strength (KN) (Avg.)	Spares Availability
05B-2	D05B 02	8.00	3.00	5.00	2.31	7.10	14.30	17.40	5.64	0.22	0.32	7.80	8.55	A,B,C,D
06B-2*	D061 02	9.525	5.72	6.35	3.28	8.20	23.80	27.10	10.24	0.56	0.76	16.90	19.25	A,B,C,D
08B-2	D083 02	12.70	7.75	8.51	4.45	11.80	31.00	34.90	13.92	1.00	1.31	32.00	38.05	A,B,C,D
10B-2	D101 02	15.875	9.65	10.16	5.08	14.70	36.20	40.30	16.59	1.34	1.79	44.50	57.30	A,B,C,D
12B-2	D120 02	19.05	11.68	12.07	5.72	16.10	42.20	46.80	19.46	1.76	2.22	57.80	65.70	A,B,C,D
16B-2	D160 02	25.40	17.02	15.88	8.27	21.00	68.00	73.40	31.88	4.14	5.03	106.00	137.55	A,B,C,D
20B-2	D200 02	31.75	19.56	19.05	10.19	26.40	79.00	85.10	36.45	5.82	7.33	170.00	210.00	A,B,C,D
24B-2	D240 02	38.10	25.40	25.40	14.63	33.40	101.00	107.60	48.36	10.98	13.50	280.00	322.50	B,C,D
28B-2	D280 02	44.45	30.99	27.94	15.90	37.00	124.00	131.40	59.56	14.52	16.96	360.00	412.60	B,C,D
32B-2	D320 02	50.80	30.99	29.21	17.81	42.20	126.00	133.90	58.55	16.10	18.74	450.00	510.80	B,C,D
40B-2	D400 02	63.50	38.10	39.37	22.89	52.90	154.00	164.00	72.29	25.23	30.72	630.00	708.10	B,C,D
48B-2	D480 02	76.20	45.72	48.26	29.24	63.80	190.00	200.00	91.21	40.81	48.54	1000.00	1100.00	B,C,D

* Straight Side Plates

Note : Spares E & F are available for all models

STANDARD ROLLER CHAINS



ISO 606/BS 228/DIN 8187

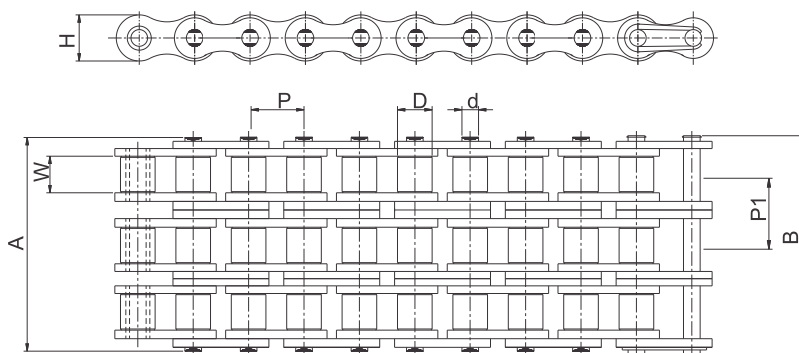

TRIPLE STRAND

Intl. Ref No.	ROMBO Chain No.	Pitch (P)	Width between Inner Plates (W) (Min)	Roller Dia (D) (Max)	Bearing Pin Dia (D) (Max)	Plate Height (H) (Max)	Width over Bearing Pin (A) (Max)	Width over Joint Fasteners (B) Max	Transverse Pitch (P1)	Projected bearing Area Sq.cm	Avg. Weight Per Meter (Kg)	Tensile Strength (KN) (Min)	Tensile Strength (KN) (Avg)	Spares Availability
05B-3	D05B 03	8.00	3.00	5.00	2.31	7.10	19.90	23.00	5.64	0.33	0.50	11.10	12.20	A,B,C,D
06B-3*	D061 03	9.525	5.72	6.35	3.28	8.20	34.00	37.30	10.24	0.84	1.12	24.90	27.70	A,B,C,D
08B-3*	D083 03	12.70	7.75	8.51	4.45	11.80	44.90	48.80	13.92	1.50	1.94	47.50	56.00	A,B,C,D
10B-3	D101 03	15.875	9.65	10.16	5.08	14.70	52.80	56.90	16.59	2.01	2.68	66.70	83.35	A,B,C,D
12B-3	D120 03	19.05	11.68	12.07	5.72	16.10	61.70	66.30	19.46	2.64	3.32	86.70	101.55	A,B,C,D
16B-3	D160 03	25.40	17.02	15.88	8.27	21.00	99.90	105.30	31.88	6.21	7.65	160.00	202.80	A,B,C,D
20B-3	D200 03	31.75	19.56	19.05	10.19	26.40	116.00	122.10	36.45	8.73	10.96	250.00	306.55	A,B,C,D
24B-3	D240 03	38.10	25.40	25.40	14.63	33.40	150.00	156.60	48.36	16.47	20.20	425.00	490.60	B,C,D
28B-3	D280 03	44.45	30.99	27.94	15.90	37.00	184.00	191.40	59.56	21.78	25.38	530.00	625.95	B,C,D
32B-3	D320 03	50.80	30.99	29.21	17.81	42.20	184.00	191.90	58.55	24.15	28.04	670.00	775.00	B,C,D
40B-3	D400 03	63.50	38.10	39.37	22.89	52.90	227.00	237.00	72.29	37.85	45.97	950.00	1088.90	B,C,D
40B-3	D480 03	76.20	45.72	48.26	29.24	63.80	281.00	291.00	91.21	61.22	72.67	1500.00	1648.10	B,C,D

* Straight Side Plates

Note : Spares E & F are available for all models

CERTIFICATE

Management system as per
ISO 14001 : 2004

In accordance with TÜV NORD CERT procedures, it is hereby certified that

TIDC INDIA
(UNIT OF TUBE INVESTMENT OF INDIA LIMITED)
Survey No. 264, 268/1, 268/2A, 268/2B, 269/1 & 2,
CTH Road, Ambattur, Chennai- 600 053,
Tamilnadu, India



applies a management system in line with the above standard for the following scope

Manufacture of Automotive, Industrial, Agricultural & Cam Chains, Engineering Class Chain, Fine Blanking components & Accessories

Certificate Registration No. 44 104 114274 -E3
Audit Report No. 2.5-1490/1999

Valid until 17.07.2014

Certification Body
at TÜV NORD CERT GmbH

Mumbai, 18.07.2011

This certification was conducted in accordance with the TÜV NORD CERT auditing and certification procedures and is subject to regular surveillance audits.
TÜV NORD CERT GmbH Langemarkstrasse 20 45141Essen www.tuv-nord-cert.com



CERTIFICATE

Management system as per
BS OHSAS 18001 : 2007

In accordance with TÜV NORD CERT procedures, it is hereby certified that

TIDC INDIA
(UNIT OF TUBE INVESTMENT OF INDIA LIMITED)
Survey No. 264, 268/1, 268/2A, 268/2B, 269/1 & 2,
CTH Road, Ambattur, Chennai-600 053, Tamilnadu,
India
with the location
TIDC INDIA, Andhra Pradesh, India
TIDC INDIA, Uttarakhand, India



applies a management system in line with the above standard for the following scope

Manufacture of Automotive, Industrial, Agricultural & Cam Chains, Engineering Class Chain, Fine Blanking components & Accessories

Certificate Registration No. 44 116 111314
Audit Report No. 3508 2944

Valid until 2014.07.06

Certification Body
at TÜV NORD CERT GmbH

Essen, 2011.07.07

This certification was conducted in accordance with the TÜV NORD CERT auditing and certification procedures and is subject to regular surveillance audits.

TÜV NORD CERT GmbH Langemarkstrasse 20 45141Essen www.tuv-nord-cert.com



CERTIFICATE

Management system as per
DIN EN ISO 9001 : 2008

In accordance with TÜV NORD CERT procedures, it is hereby certified that

TIDC INDIA
Plot No. 11, Ambattur,
Chennai - 600 053,
India
and other locations as per Annexure 1



applies a management system in line with the above standard for the following scope

Design, Manufacture and Supply of Standard Roller Chains, Bush Chains, Leaf Chains, Special Chains, Sprockets, Road Chains, Agricultural Chains, Conveyor Chains, Engineering Class Chains, Sprockets and Accessories, Manufacture and supply of Fine Blanking Parts (Components and Sub-Assemblies)

Certificate Registration No. 44 116 011983
Audit Report No. 3511/1999

Valid until 2014

Certification Body
at TÜV NORD CERT GmbH

Mumbai, 18.07.2011

This certification was conducted in accordance with the TÜV NORD CERT auditing and certification procedures and is subject to regular surveillance audits.

TÜV NORD CERT GmbH Langemarkstrasse 20 45141Essen www.tuv-nord-cert.com



- ♦ All dimensions indicated are in mm.
- ♦ All information contained in this catalogue is subject to change after publication.
- ♦ While all reasonable care has been taken in compiling the information contained in this catalogue, no responsibility is accepted for printing errors.



TIDC INDIA

Unit of Tube Investments of India Ltd.

FACTORY / MARKETING HEAD OFFICE :

Post Bag No.11, Ambattur, Chennai - 600 053.
Tel. : 044 - 4223 5508 / 509 Fax : 044 - 4223 5556
Email : industrialchains@tii.murugappa.com
www.tidcindia.in

NORTH

TIDC INDIA

2nd Floor, Jeevan Deep Building,
10, Parliament Street,
New Delhi - 110 001.
Tel. : 011 - 4150 2244

SOUTH

TIDC INDIA

Post Bag No. 11, Ambattur,
Chennai - 600 053.
Tel. : 044 - 4223 5500

EAST

TIDC INDIA

Chabbildas Towers, 2nd Floor,
6A, MiddleTon Street,
Kolkatta - 700 071.
Tel. : 033 - 2281 0289

WEST

TIDC INDIA

302-A, M.P.J. Chambers,
Wakadewadi, Opp. to Centuri TVS,
Pune - 411 003.
Tel. : 020 - 2581 3170