



Aiding motion in every industry



CHAINS FOR AUTOMOBILE INDUSTRY



**ENGINEERING
CLASS CHAINS**

TIDC INDIA

**THE COMPLETE
CHAIN COMPANY**



TIDC engineers use Auto CAD, Solid works and Finite Element Analysis for cutting edge solution in the design of the chains, and the manufacturing technology process is plotted out with equal care. The resulting products are comprehensively tested at our labs, before they eventually find their way to a Diamond Customer.

A Trusted Brand in Conveyor Chains

The company has enormous strengths in conveyor chains, making chains for various applications in different Industries.

TIDC Means chains with more strength

Strict and complete adherence to consistent quality and regular technology up gradation have ensured TIDC chains exceed all laid down parameters

- High strength – higher breaking load. TIDC chains are tested for higher breaking load values than the international standard, endowing them with extra strength you can count on.
- Tough construction – to withstand shock load conditions common in rugged applications. TIDC has the edge in raw materials, design as well as manufacturing processes that enables us to build chains that are more rugged.
- High tensile strength – certain applications call for chains with better tensile strength, and TIDC works this feature into their products at every stage of production.
- Attachment – regular and made to order attachments are offered based on client needs.

Quality, the TIES THAT Bind Everything

Total Quality Management is a governing principle at TIDC India and we have our own quality system in place called 'TIES' (T.I. Excellence System)

TIDC India – The complete chain Company

Diamond India chains are designed and manufactured by TIDC India, a part of the prestigious Murugappa Group, one of the most trusted and respected business groups in India. A Group that is renowned for its belief in ethical business practices, innovative processes and people development.

Over six decades, TIDC has built chains for virtually every sector of industry. From tiller chains, agricultural chains, leaf chains and conveyor chains to industrial power drive chains, motorcycle drive chains and engine mechanism chains, our expertise is moving men and material across every sphere of life. And today, we possess the capability to meet any requirements in chains, anywhere in the world.

Our Strength : R & D

At TIDC, we owe our success to continuous improvement. Innovating products that suit customer needs better, makes us to constantly improve. Every choice with regards to size, material or method is in direct response to the needs of application engineers in the industries we serve.



encompassing all aspects of functioning. Beginning with the design phase, purchase and inspection of raw materials, vendor management, work instructions and going on to cover all processes in manufacturing, packing and inspections before delivery.

TIES also provides for stringent procedures when it comes to traceability of products and reviews of customer feedback.

The TIES system functions by nurturing quality as an integral part in the entire value chain, and is now completely internalized by the company.

The Best Certificates are Those that comes from our clients

We are one of the world's few companies to be certified for API 7F specifications by the American petroleum Institute for oil field chains.

Our manufacturing processes right from product design to testing of finished chains conform to ISO 9000:2000 standards and are certified by RWTUV of Germany. Our Motorcycle Engine Mechanism Chain and Fine Blanking Divisions are certified to TS 16949 standards by underwriters Laboratories, USA.

But what gives us the most pride is, the approval and repeat orders that comes to us from our clients all over India & across the world.

Product Leadership

Customers turn to TIDC for products that are designed for high performance, expanded equipment life and enhanced productivity. If you need chains that operate reliably in challenging environments, TIDC is the right source.

We apply our decades of research, engineering, manufacturing and service knowhow for every application. Because of our own performance

advantages, large OEMs turn to TIDC for products and support. This same OEM quality is offered to our after market products. That is why you will find our chains used in every tough applications.

TIDC engineers are committed to understanding your process and solve unique application problems. We work with you to optimize chain performance in the above stated products.

We use this spirit of collaboration to develop customized power transmission solutions.

Great Fatigue and Tensile Strength

The plates in each and every TIDC chain undergo piercing operation to extremely accurate specifications. Followed by Shaving or Drifting to increase bearing area, guaranteeing greater dynamic strength and fatigue life.

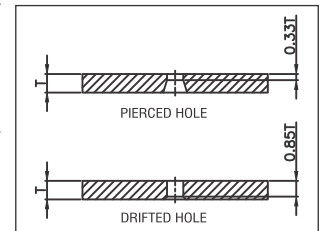

Longer Wear Life

Roundness of the bushes and heat treatment of pins and bushes impact wear life. At TIDC bushes and pins are produced using numerically controlled machines which produces them with greater accuracy.

Heat Treatment



Heat treatment is our core competency at TIDC. Our team has rich experience in heat treatment to maximize strength and life in every chain elements: pins, bushing, rollers and link plates. We deploy our specialist skills in continuous hardening operations for martensitic heat treatment. Under a completely automated atmosphere we work with high, medium and low carbon steels, alloy steels, austenitic and martensitic stainless steels etc. Other treatments we offer based on customer specifications are:

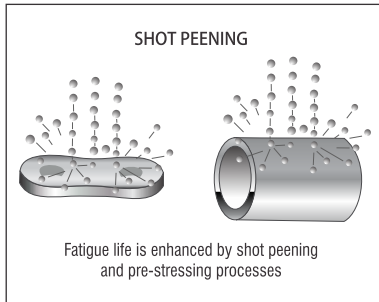

Shot peening for Maximum Load Capability/Shot Peening

Critical applications call for chains with high working load capability, plates and rollers are shot peened after heat treatment thereby increasing fatigue life. It is done by constantly bombarding the component with hard metal pellets at high speeds.

Corrosion Resistance

TIDC offers plating options, for corrosion resistance and enhanced product life – chromised pins have been proven to improve performance dramatically.



Testing

TIDC has immense capabilities for testing to validate the quality of their products. Every batch goes through stringent testing protocol, which covers fatigue tests, corrosion tests and much more. TIDC conveyor chains are built to exceed international standards, and this performance level is meticulously tested before the products reach you.



SLAT CONVEYOR CHAINS

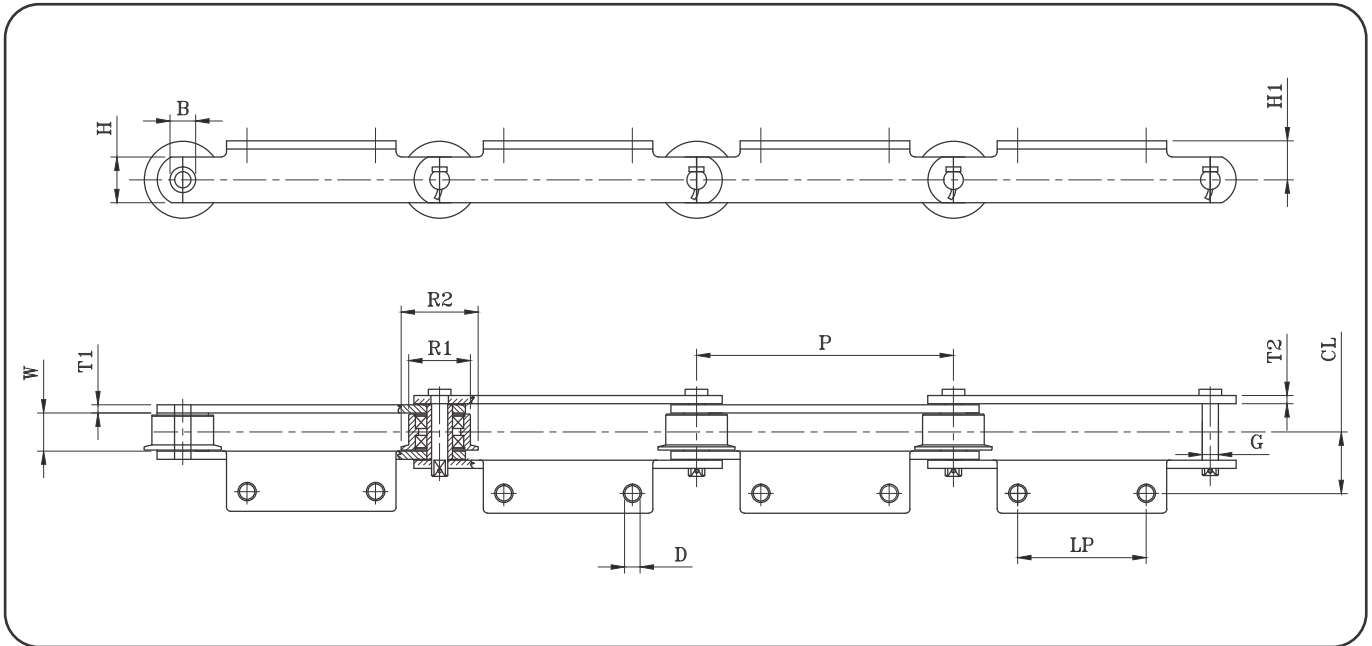

TIDC DRG.NO.	Pitch (P)	WIP (W)	Plate Width (H)	I/P Thk. (T1)	O/P Thk. (T2)	ROLLER		FLANGED ROLLER		Pin Diameter (G)	Minimum Breaking Load, Kgs	Attachment Details				SPECIAL COATING	
						Chain Roller	Body Diameter (R1)	Flanged Diameter (R2)	Bush Diameter (B)			Attachment Type	Attachment Height (H1)	Distance Bet Chain center and Lug hole (CL)	Lug hole Pitch (LP)	Coating	Components
SP 1936	102.00	19.05	30.00	4.00	4.00		36.00	44.50	16.00	10.00	8000	A2	35.00	36.00	40.00	No	
S 15000 70 SC A2 1L	150.00	30.00	40.00	6.00	6.00		48.00	63.00	18.00	11.10	11500	A2	38.00	50.00	60.00	ZAC	Plates
SP 2057	152.40	30.20	38.10	6.30	6.30		50.80	65.00	18.00	11.10	7200	A2	32.00	50.00	60.00	No	
SP 2063	152.40	76.20	65.00	12.70	12.70		75.50	95.00	35.00	25.40	50000	A2	38.10	101.70	65.00	No	
SP 2099	152.40	30.20	38.10	6.30	6.30		50.80	65.00	18.00	11.10	7200	A2	35.00	50.00	60.00	No	
S15240 27 SC A2 1L	152.40	28.00	38.10	6.30	6.30		50.80	64.50	18.00	11.10	7200	A2	28.55	50.00	60.00	No	
SP 1900	200.00	30.00	40.00	8.00	8.00	30.00	50.00	65.00	17.00	12.00	12000	A2	75.00	65.00	80.00	BLACKENED	Plates & Pin
SP 2058	200.00	37.10	44.50	8.00	8.00		65.00	80.00	25.00	15.90	19000	A2	38.00	60.00	65.00	No	
SP 2088	200.00	37.10	44.50	8.00	8.00		65.00	80.00	25.00	15.90	17000	A2	38.00	60.00	80.00	No	
SP 2103	200.00	27.00	32.00	6.00	6.00		44.50	55.00	15.00	9.54	8000	A2	28.00	50.00	80.00	No	
SP 2286	200.00	37.10	44.50	8.00	8.00		65.00	80.00	25.00	15.90	19000	A2	44.00	60.00	80.00	No	
SP 2325	200.00	33.00	32.00	6.00	6.00		50.80	63.00	18.00	10.00	11500	A2	45.00	55.00	80.00	BLACKENED	All Parts
SP 2341	200.00	37.10	44.50	8.00	8.00		65.00	80.00	25.00	15.90	19000	A2	38.00	60.00	65.00	No	
S20000 31 SC A2 1L	200.00	33.00	32.00	6.00	6.00		50.00	63.00	15.00	10.00	10250	A2	45.00	55.00	80.00	BLACKENED	All Parts
S22860 11 SC A2 1L	228.60	50.80	50.00	10.00	10.00		88.90	111.00	30.00	19.10	18500	A2	64.00	73.20	88.90	No	
SP 1929	250.00	31.30	40.00	8.00	8.00	32.00	50.00	65.00	19.00	13.00	11500	A2	85.00	70.00	125.00	BLACKENED	Plates & Pin
SP 2078	250.00	37.10	44.50	8.00	8.00		65.00	80.00	25.00	15.90	19000	A2	43.00	60.00	65.00	No	
SP 2092	250.00	37.10	44.50	8.00	8.00		65.00	80.00	25.00	15.90	19000	A2	43.00	60.00	120.00	No	
SP 2117	250.00	37.10	44.50	8.00	8.00		65.00	80.00	25.00	15.90	19000	A2	43.00	60.00	120.00	No	
SP 2136	250.00	51.40	50.80	10.00	10.00		80.00	100.00	27.00	19.10	25000	A2	45.00	72.00	125.00	ZAC	Plates
SP 2179	250.00	38.30	40.00	6.00	6.00		50.00	65.00	22.00	12.00	8000	A2	38.00	71.00	124.00	No	
SP 2284	250.00	31.30	40.00	6.00	6.00	32.00	50.00	65.00	17.00	12.00	11500	A2	85.00	70.00	125.00	BLACKENED	All Parts
SP 2342	250.00	37.10	44.50	8.00	8.00		65.00	80.00	24.85	15.90	19000	A2	38.00	60.00	65.00	No	
SP 2345	250.00	37.10	44.50	6.30	6.30		65.00	80.00	25.00	15.90	19000	A2	38.00	60.00	65.00	No	
SP 2356	250.00	32.00	45.00	8.00	8.00	35.00	50.80	65.00	24.00	17.50	14000	A2	50.00	7.50	130.00	No	
S25000 13 SC A2 1L	250.00	37.10	44.50	8.00	8.00		65.00	80.00	25.00	15.90	17000	A2	38.00	60.00	125.00	ZAC	All Parts
S25000 16 SC WA2 1L	250.00	37.00	50.00	8.00	8.00	65.00			25.00	18.00	20000	WA2	30.00	59.75	80.00	No	
SP 1930	300.00	37.00	50.00	8.00	8.00	46.00	70.00	80.00	34.18	25.00	15000	A2	80.00	60.00	125.00	BLACKENED	All Parts
SP 2189	300.00	51.40	50.80	10.00	10.00		80.00	100.00	27.00	19.10	27000	A2	45.00	75.00	125.00	ZAC	Plates
SP 2197	300.00	37.00	50.00	6.00	6.00		70.00	80.00	34.20	25.00	13000	A2	80.00	60.00	125.00	BLACKENED	All Parts
SP 2265	300.00	37.00	50.00	8.00	8.00	46.00	70.00	80.00	34.18	25.00	15000	A2	80.00	60.00	125.00	BLACKENED	All Parts
SP 2343	300.00	37.10	44.50	8.00	8.00		65.00	80.00	24.85	15.90	19000	A2	38.00	60.00	65.00	No	

SLAT CONVEYOR CHAINS

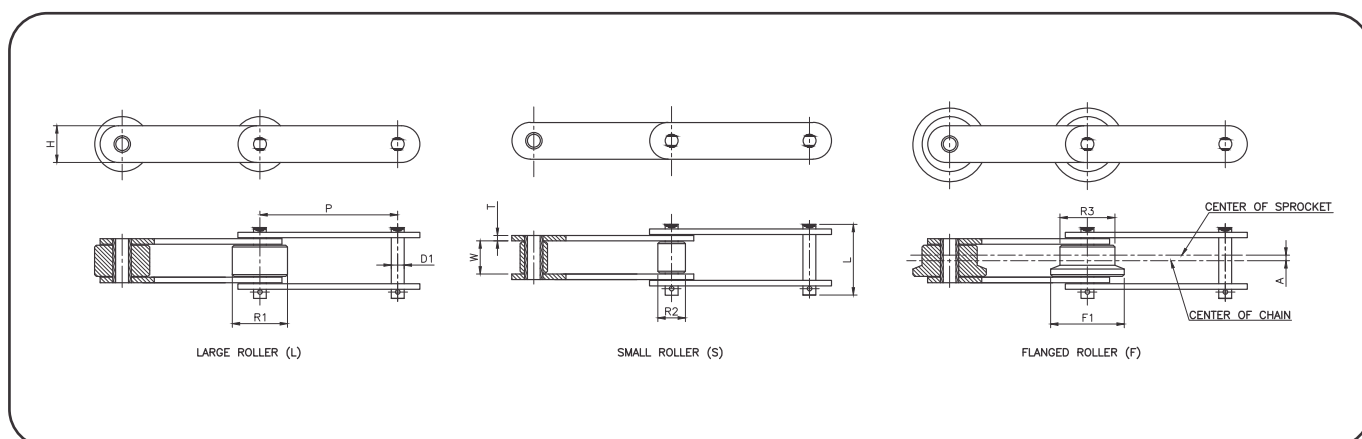

Chain No.	Pitch P	Roller Type Type	Large Roller Dia. R1	Small Roller Dia R2	Flanged Roller Dia R3	Flange Dia. F1	Dist Bet. Centers A	WIP W	PIT HT. H	PIL Thk. T	Avg Brk. Load	Min Brk. Load KGF	Pin Dia. D1 KGF	Pin Length L
DO 03075	75.00	L,FS	31.80	15.90	31.80	42.00	4.30	16.10	22.00	3.2	3000	2550	8.0	38
DO 03100	100.00	L,FS	31.80	15.90	31.80	42.00	4.30	16.10	22.00	3.2	3000	2550	8.0	38
DO 430	101.60	L,S	40.00	20.10	-	-	-	22.60	25.40	4.8	5500	4675	9.7	55
DO 05075	75.00	S	-	22.20	40.00	50.00	4.50	22.00	32.00	4.5	7000	5950	11.3	53.5
DO 05100	100.00	L,FS	40.00	22.20	40.00	50.00	4.50	22.00	32.00	4.5	7000	5950	11.3	53.5
DO 05150	150.00	L,FS	40.00	22.20	40.00	50.00	4.50	22.00	32.00	4.5	7000	5950	11.3	53.5
DO 204	66.27	S	-	22.20	-	-	-	27.00	28.60	6.3	8000	6800	11.3	65.5
DO 450	101.60	L,FS	44.50	22.20	44.50	55.00	6.50	27.00	28.60	6.3	8000	6800	11.3	65.5
DO 08150	150.00	L,FS	44.50	22.20	44.50	55.00	6.50	27.00	28.60	6.3	8000	6800	11.3	65.5
DO 650	152.40	L,FS	50.80	25.80	50.80	65.00	7.00	30.20	38.10	6.3	8000	6800	11.3	69
DO 10100	100.00	L,S	50.80	29.00	-	-	-	30.00	38.10	6.3	11500	9775	14.5	69
DO 10150	150.00	L,FS	50.80	29.00	50.80	65.00	7.00	30.00	38.10	6.3	11500	9775	14.5	69
DO 214	101.60	L,S	44.50	31.80	-	-	-	31.60	38.10	7.9	13000	11050	15.9	77.5
DO 205	78.11	S	-	31.80	-	-	-	37.10	38.10	7.9	13000	11050	15.9	83.5
DO 6205	152.40	L,FS	57.20	34.90	57.20	70.00	9.00	37.10	44.50	7.9	19000	16150	15.9	83.5
DO 12200	200.00	L,FS	65.00	34.90	65.00	80.00	8.00	37.10	44.50	7.9	19000	16150	15.9	83.5
DO 12250	250.00	L,FS	65.00	34.90	65.00	80.00	8.00	37.10	44.50	7.9	19000	16150	15.9	83.5
DO 212	152.40	L,S	69.90	40.10	-	-	-	37.10	50.80	9.5	25000	21250	19.1	95.5
DO 17200	200.00	L,FS	80.00	40.10	80.00	100.00	12.00	51.40	50.80	9.5	25000	21250	19.1	109.5
DO 17250	250.00	L,FS	80.00	40.10	80.00	100.00	12.00	51.40	50.80	9.5	25000	21250	19.1	109.5
DO 17300	300.00	L,FS	80.00	40.10	80.00	100.00	12.00	51.40	50.80	9.5	25000	21250	19.1	109.5
DO 26200	200.00	S	-	44.50	-	-	-	57.20	63.50	9.5	32000	27200	22.2	116.5
DO 26250	250.00	L,FS	100.00	44.50	100.00	125.00	13.00	57.20	63.50	9.5	32000	27200	22.2	116.5
DO 26300	300.00	L,FS	100.00	44.50	100.00	125.00	13.00	57.20	63.50	9.5	32000	27200	22.2	116.5
DO 26450	450.00	L,FS	100.00	44.50	100.00	125.00	13.00	57.20	63.50	9.5	32000	27200	22.2	116.5
DO 36250	250.00	S	-	50.80	-	-	-	66.70	76.20	12.7	48500	41225	25.4	146
DO 36300	300.00	L,FS	125.00	50.80	125.00	150.00	14.00	66.70	76.20	12.7	48500	41225	25.4	146
DO 36450	450.00	L,FS	125.00	50.80	125.00	150.00	14.00	66.70	76.20	12.7	48500	41225	25.4	146
DO 36600	600.00	L,FS	125.00	50.80	125.00	150.00	14.00	66.70	76.20	12.7	48500	41225	25.4	146
DO 52300	300.00	L,FS	140.00	57.20	140.00	170.00	16.50	77.00	76.20	16.0	51000	43350	31.8	172
DO 52450	450.00	L,FS	140.00	57.20	140.00	170.00	16.50	77.00	76.20	16.0	51000	43350	31.8	172
DO 52600	600.00	L,FS	140.00	57.20	140.00	170.00	16.50	77.00	76.20	16.0	51000	43350	31.8	172
DO 60300	300.00	L,FS	140.00	70.00	140.00	170.00	16.50	77.00	90.00	12.7	51000	43350	35.0	160.5
DO 60350	350.00	L,FS	140.00	70.00	140.00	170.00	16.50	77.00	90.00	12.7	51000	43350	35.0	160.5
DO 60400	400.00	L,FS	140.00	70.00	140.00	170.00	16.50	77.00	90.00	12.7	51000	43350	35.0	160.5
DO 90350	350.00	S	-	85.00	-	-	-	88.00	110.00	16.0	80500	68425	42.0	189.5
DO 90400	400.00	L,FS	170.00	85.00	170.00	205.00	18.00	88.00	110.00	16.0	80500	68425	42.0	189.5
DO 90500	500.00	L,FS	170.00	85.00	170.00	205.00	18.00	88.00	110.00	16.0	80500	68425	42.0	189.5
DO 120400	400.00	L,S	200.00	100.00	-	-	-	100.00	130.00	19.0	113000	96050	50.0	218.5
DO 120600	600.00	L,FS	200.00	100.00	200.00	240.00	20.50	100.00	130.00	19.0	113000	96050	50.0	218.5

INTEGRAL ATTACHMENTS

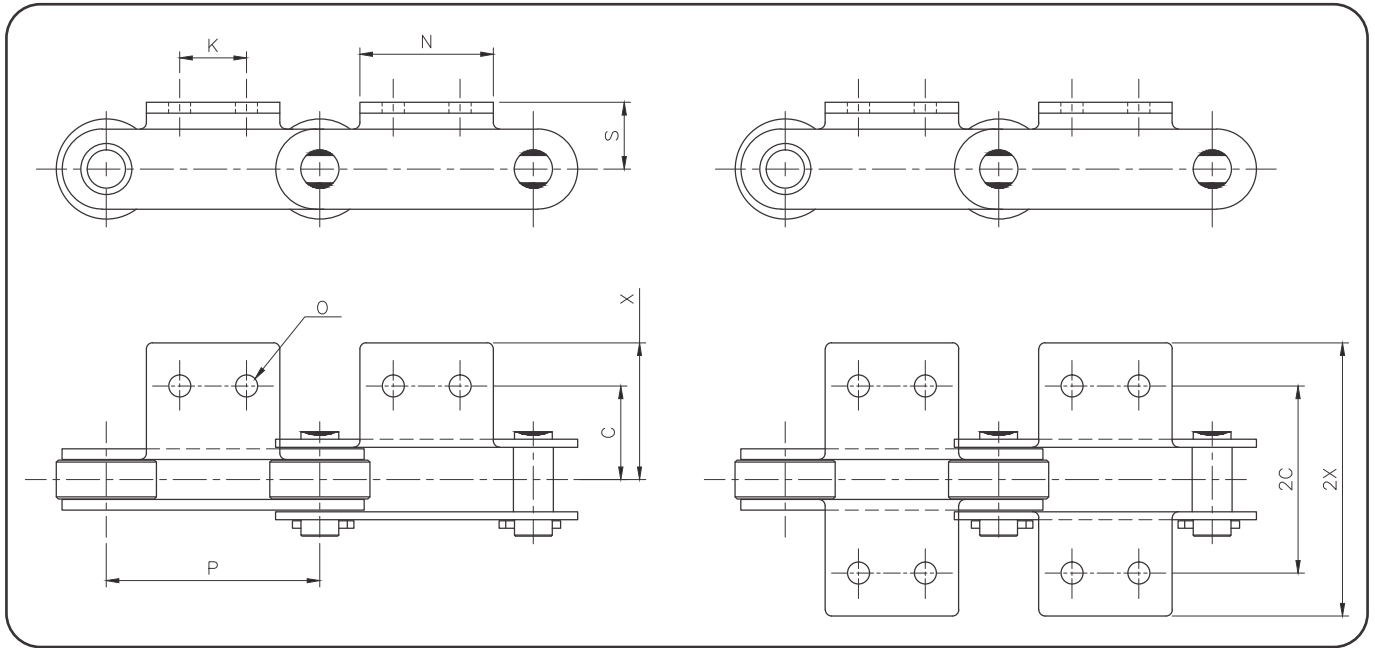

Chain No	Pitch P	Roller Type	S	C	2C	X	2X	K	N	O
DO 03075	75.00	L,F,S	20.00	30.00	60.00	46.00	92.00	30.00	55.00	10.0
DO 03100	100.00	L,F,S	20.00	30.00	60.00	46.00	92.00	40.00	65.00	10.0
DO 430	101.60	L,S	22.00	40.00	80.00	54.00	108.00	40.00	70.00	12.0
DO 05075	75.00	S	22.00	35.00	70.00	52.00	104.00	30.00	55.00	10.0
DO 05100	100.00	L,F,S	22.00	35.00	70.00	52.00	104.00	40.00	65.00	10.0
DO 05150	150.00	L,F,S	22.00	35.00	70.00	52.00	104.00	60.00	85.00	10.0
DO 204	66.27	S	24.00	45.00	90.00	59.00	118.00	-	35.00	12.0
DO 450	101.60	L,F,S	28.00	50.00	100.00	64.00	128.00	40.00	70.00	12.0
DO 08150	150.00	L,F,S	28.00	50.00	100.00	64.00	128.00	60.00	90.00	12.0
DO 650	152.40	L,F,S	32.00	50.00	100.00	64.00	128.00	60.00	90.00	12.0
DO 10100	100.00	L,S	28.00	50.00	100.00	65.00	130.00	40.00	70.00	12.0
DO 10150	150.00	L,F,S	28.00	50.00	100.00	65.00	130.00	60.00	90.00	12.0
DO 214	101.60	L,S	35.00	55.00	110.00	73.00	146.00	40.00	80.00	15.0
DO 205	78.11	S	35.00	60.00	120.00	75.00	150.00	30.00	65.00	12.0
DO 6205	152.40	L,F,S	38.00	60.00	120.00	79.00	158.00	60.00	100.00	15.0
DO 12200	200.00	L,F,S	38.00	60.00	120.00	79.00	158.00	80.00	120.00	15.0
DO 12250	250.00	L,F,S	38.00	60.00	120.00	79.00	158.00	125.00	170.00	15.0
DO 212	152.40	L,S	45.00	65.00	130.00	83.00	166.00	60.00	100.00	15.0
DO 17200	200.00	L,F,S	45.00	75.00	150.00	98.00	196.00	80.00	120.00	15.0
DO 17250	250.00	L,F,S	45.00	75.00	150.00	98.00	196.00	125.00	170.00	15.0

WELDED ATTACHMENTS

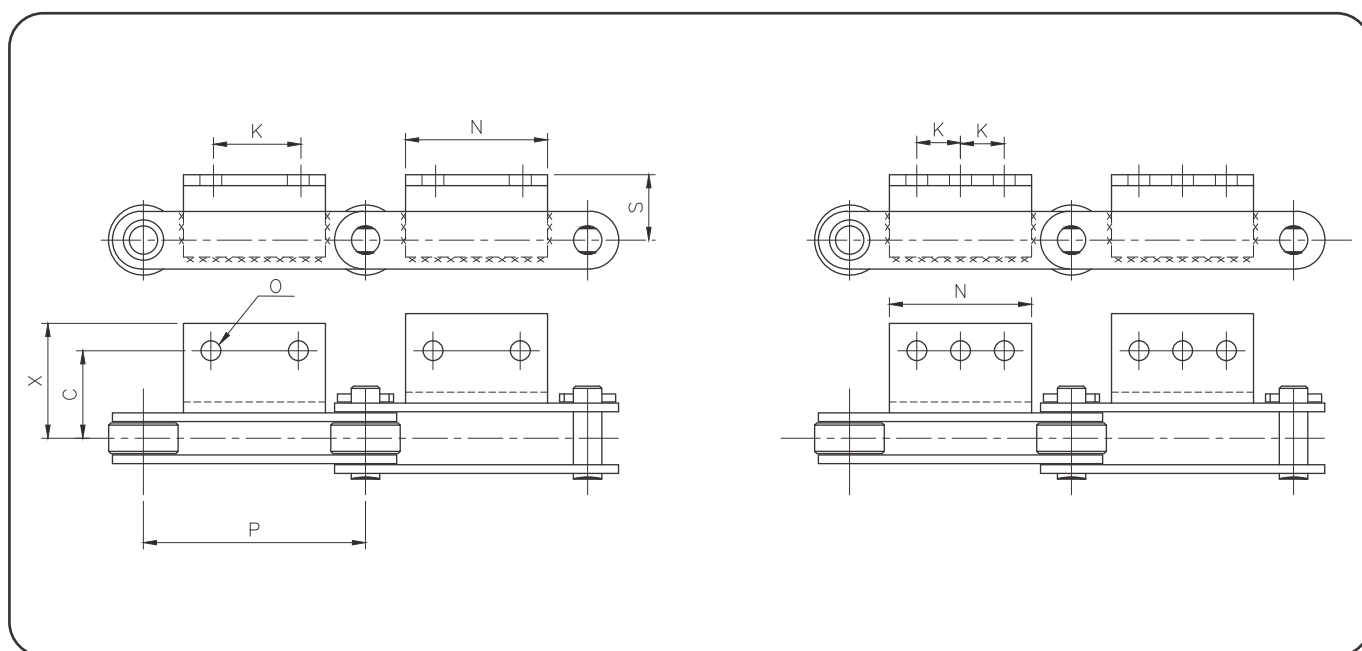

Attachment Type	Chain No	Pitch P	Roller Type	S	C	X	K	N	O	Angle Size
A2	DO 17300	300.00	L,FS	45.00	75.00	111.00	180.00	220.00	15.00	65 X 65 X 6
	DO 26300	300.00	L,FS	55.00	80.00	124.00	180.00	220.00	15.00	75 X 75 X 10
	DO 60300	300.00	L,FS	90.00	115.00	165.00	110.00	160.00	24.00	100 X 100 X 14
	DO 90350	350.00	S	100.00	140.00	210.00	100.00	180.00	28.00	130 X 130 X 16
	DO 90400	400.00	L,FS	100.00	140.00	210.00	150.00	230.00	28.00	130 X 130 X 16
DO 120400	400.00	L, S	120.00	150.00	220.00	120.00	200.00	28.00	130 X 130 X 16	
A3	DO 26450	450.00	L,FS	55.00	80.00	124.00	140.00	320.00	15.00	75 X 75 X 10
	DO 36450	450.00	L,FS	70.00	100.00	160.00	140.00	330.00	19.00	100 X 100 X 10
	DO 36600	600.00	L,FS	70.00	100.00	160.00	180.00	410.00	19.00	100 X 100 X 10
	DO 52450	450.00	L, F	80.00	120.00	171.00	140.00	330.00	24.00	100 X 100 X 14
	DO 52600	600.00	L, F	80.00	120.00	171.00	180.00	410.00	24.00	100 X 100 X 14
	DO 60350	350.00	L,FS	90.00	115.00	165.00	80.00	220.00	24.00	100 X 100 X 14
	DO 60400	400.00	L,FS	90.00	115.00	165.00	100.00	260.00	24.00	100 X 100 X 14
	DO 90500	500.00	L,FS	100.00	140.00	210.00	130.00	340.00	28.00	130 X 130 X 16
DO 120600	600.00	L,FS	220.00	150.00	220.00	160.00	400.00	28.00	130 X 130 X 1	

TOP ROLLER CHAIN

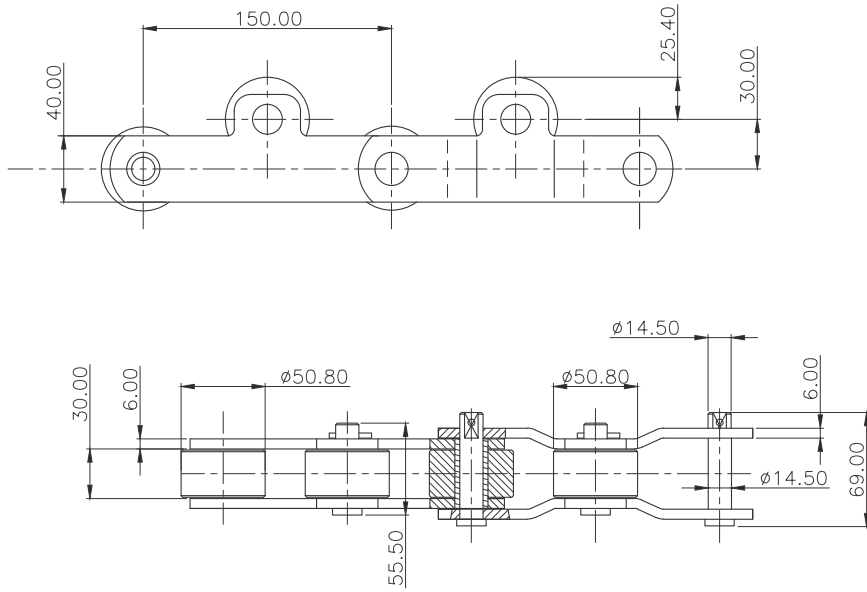

TIDC MODEL: S 15000 41 TR 1L
 MINIMUM BREAKING LOAD = 19,200 KGS

FLOOR CONVEYOR CHAIN

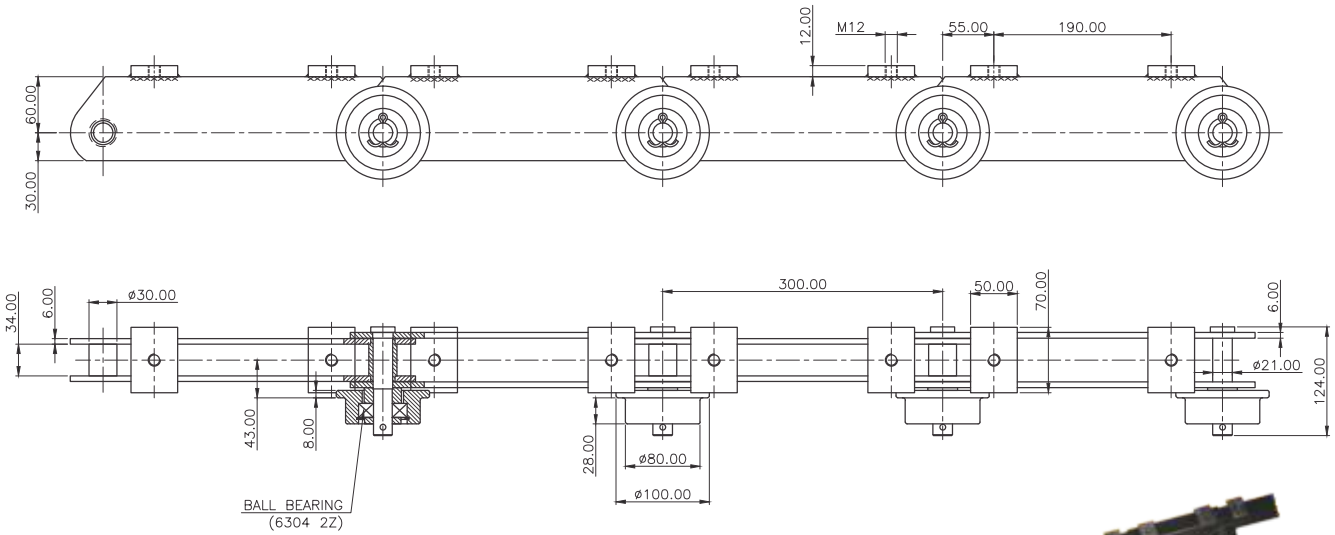

TIDC MODEL: AS 30000 12 FR
 MINIMUM TENSILE STRENGTH = 20,000 KGS



SLAT CONVEYOR CHAINS

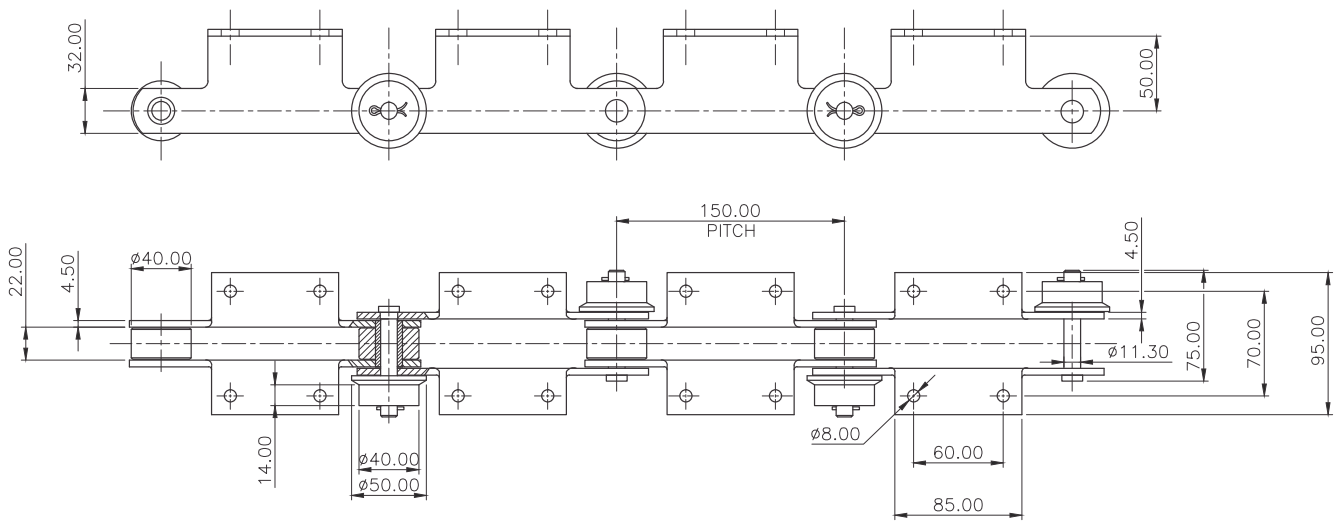

TIDC MODEL: S 15000 76 K2 1L

MINIMUM BREAKING LOAD = 8000 KGF.

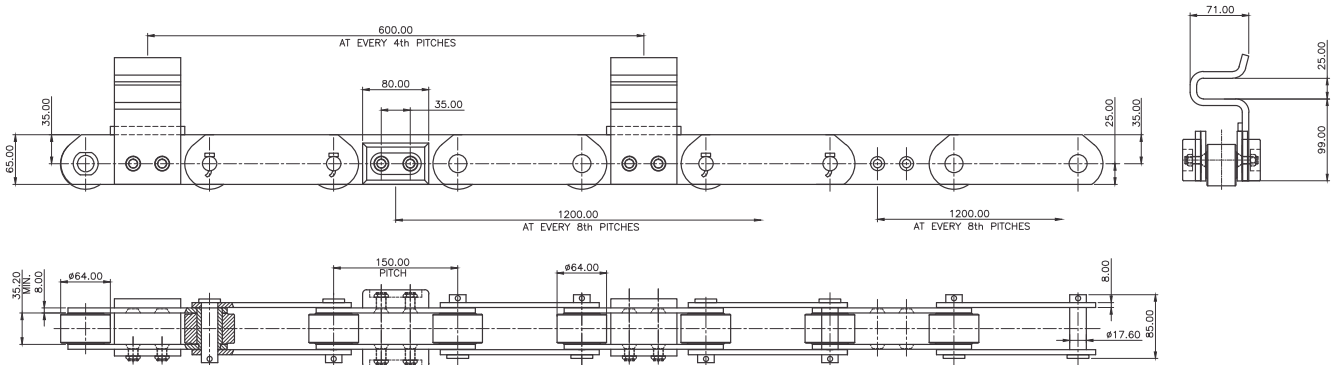

TIDC MODEL: S 15000 63 DSP BAS 2I

MINIMUM BREAKING LOAD = 20,000 KGF

SHOWER TESTER CHAINS

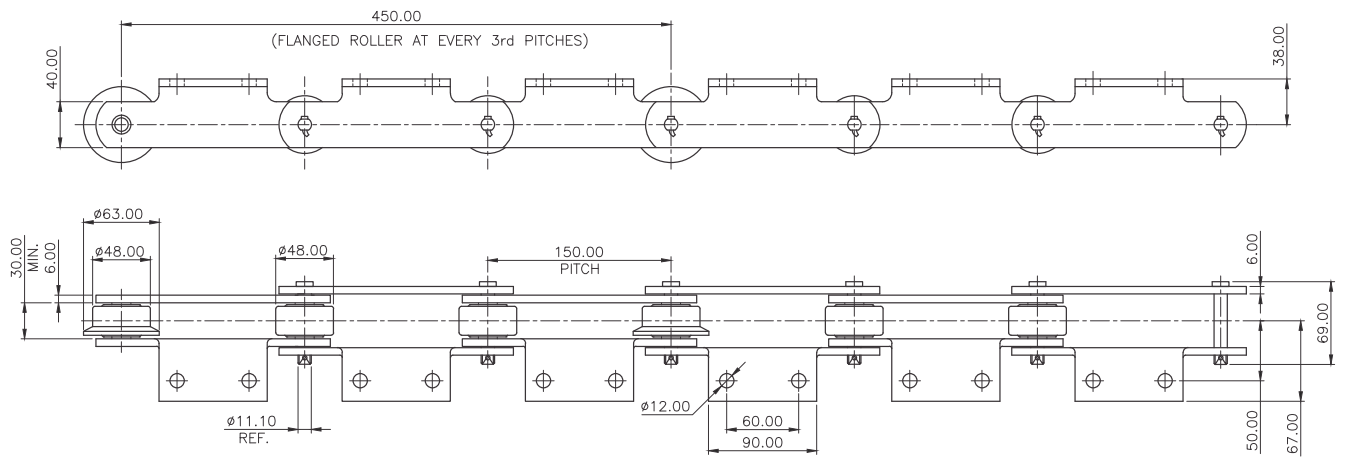

TIDC MODEL: S 15000 70 SC A2 1L

MINIMUM TENSILE STRENGTH = 11500 KGS.

PLATES: ZAC COATED
ROUND PARTS: STAINLESS STEEL

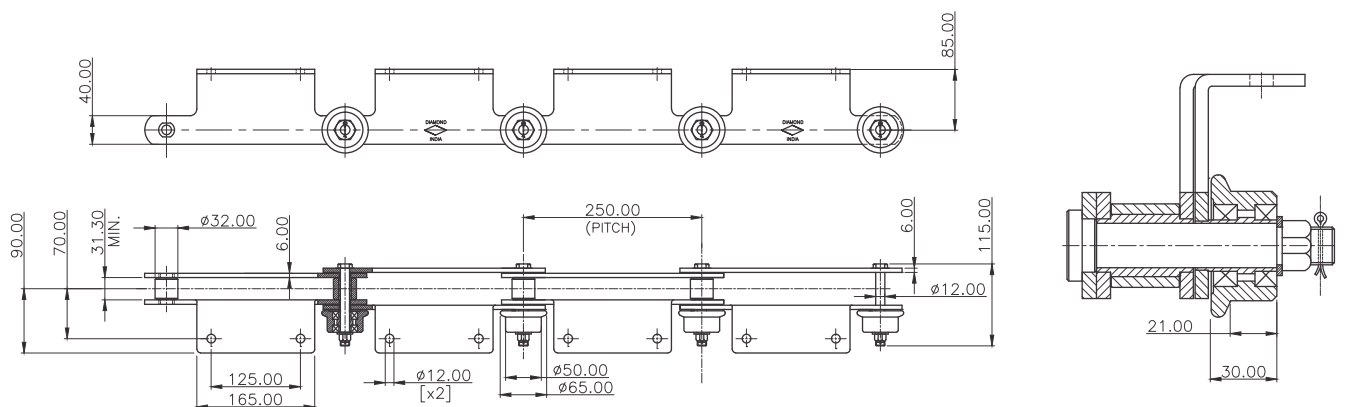

TIDC MODEL: SP 2284

MINIMUM TENSILE STRENGTH = 11,500 KGF.

ENGINE ASSEMBLY CONVEYOR CHAIN

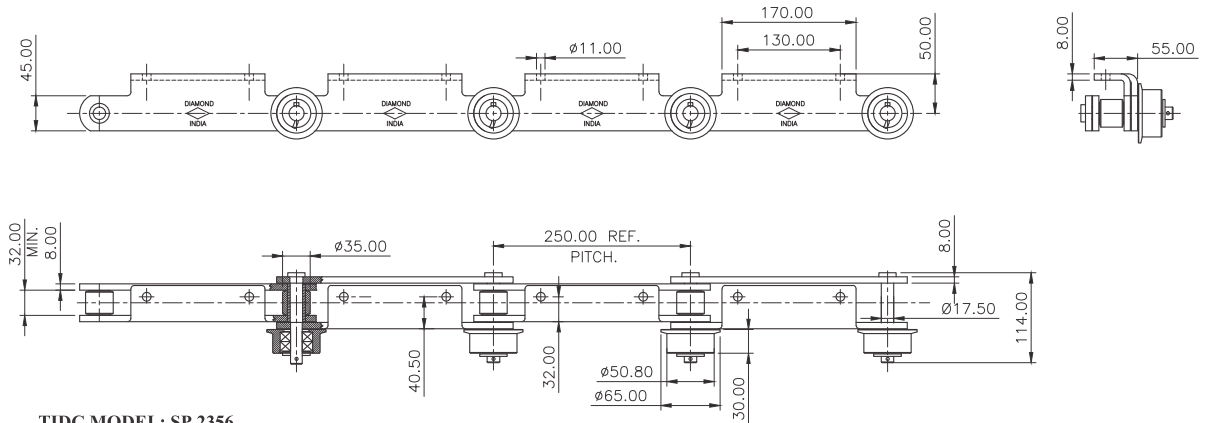

TIDC MODEL: SP 2356

MINIMUM TENSILE STRENGTH = 14,000 KGF

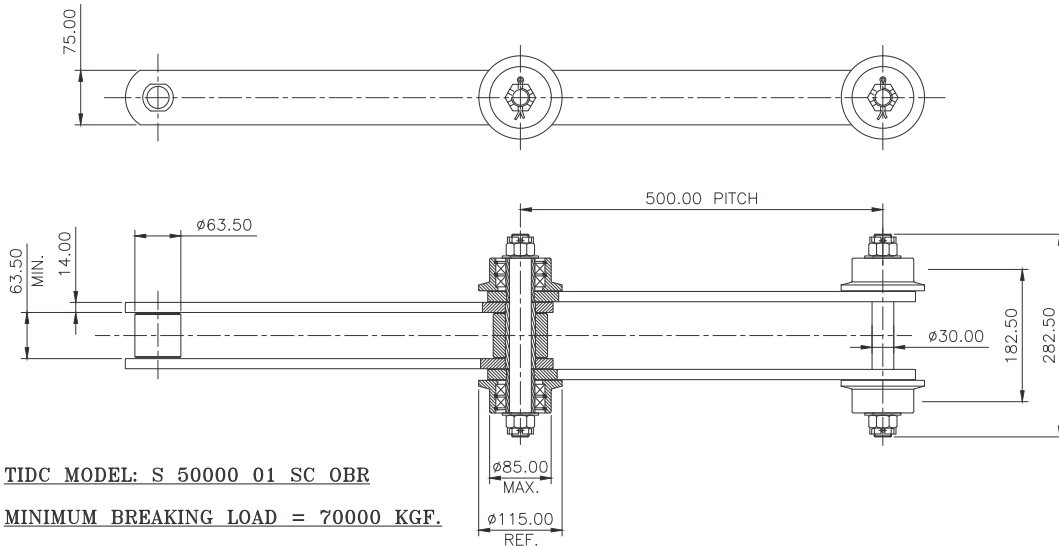

TIDC MODEL: S 50000 01 SC OBR

MINIMUM BREAKING LOAD = 70000 KGF.

WASHING CONVEYOR CHAIN

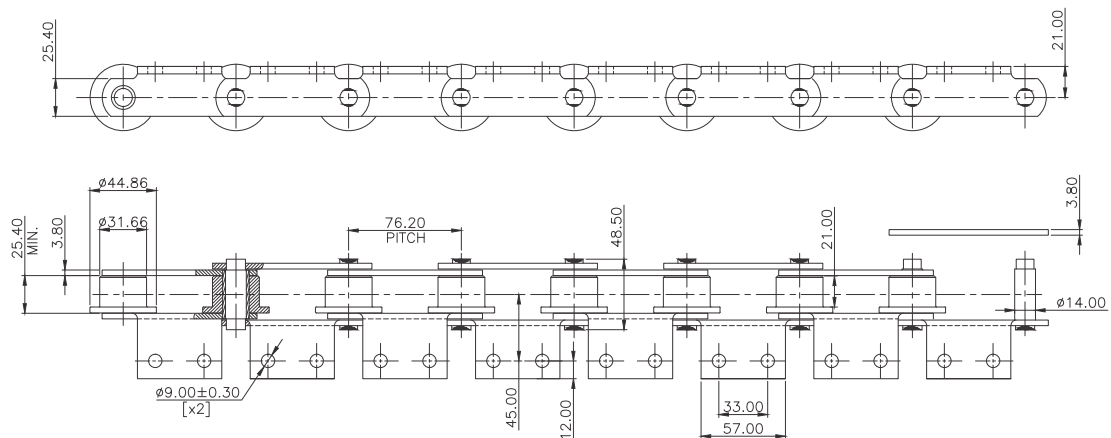

TIDC MODEL: S 07620 29 SC ZA A2 1L

MINIMUM BREAKING LOAD = 3450 KGF

ALL PARTS ZAC COATED

RIVETLESS FORGED LINK CHAINS

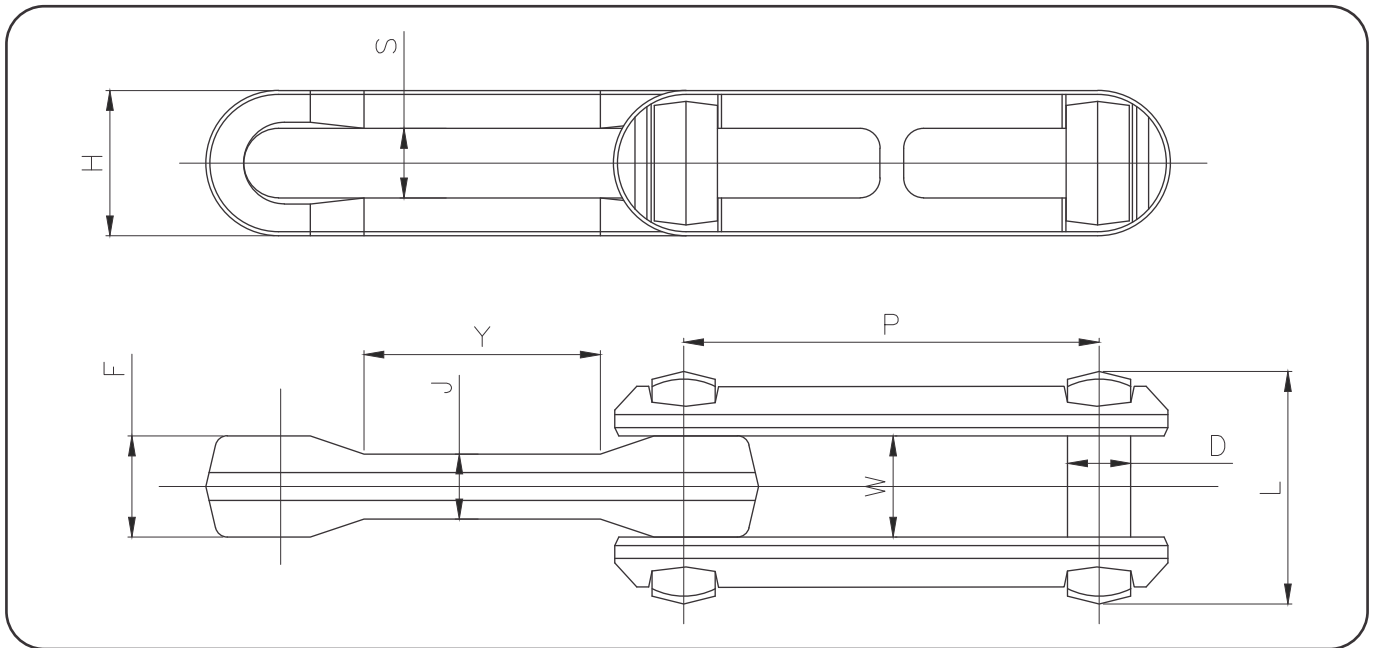

TIDC DRG. NO.	Pitch (P)	WIP (W)	Link Height (H)	Link Thickness 1 (F)	Link Thickness 2 (J)	Inner Link Straight Portion (Y)	Width (S)	Pin Diameter (D)	Pin Length (L)	Minimum Breaking Load, Kgf
S 07660 01 X348	76.60	20.10	28.00	18.80	13.00		13.50	12.40	44.00	10000
S 10240 01 X458	102.40	27.20	36.50	25.40	16.30		17.50	15.88	58.50	19000
S 15320 01 X678	153.20	34.30	51.60	32.50	21.10		24.10	22.10	77.00	32400
SP 2111	153.67	40.00	65.90	39.20	25.40	88.90	29.80	28.60	96.80	71000
SP 1954	229.40	51.00	78.00	50.00	33.50	152.00	37.20	35.00	121.00	100000
S 22860 01 FG RLS	228.60	51.00	78.00	50.00	33.50	152.00	37.20	35.00	121.00	100000
S 22938 01 FG RLS	229.38	63.00	96.80	61.91	41.27		49.21	44.45	148.00	17000

STANDARD ROLLER CHAINS

EUROPEAN SERIES



ISO 606/BS 228/DIN 8187

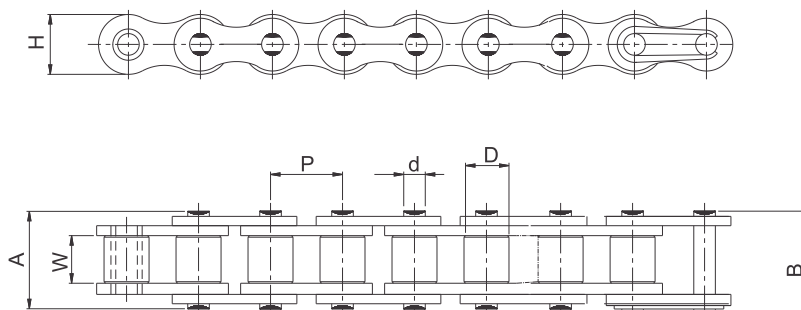

The European series of roller chains are designed for use in mechanical power transmission systems.

SINGLE STRAND

Intl. Ref No.	ROMBO Chain No.	Pitch (P)	Width between Inner Plates (W) (Min)	Roller Dia (D) (Max)	Bearing Pin Dia (D) (Max)	Plate Height (H) (Max)	Width over Bearing Pin (A) (Max)	Width over Joint Fasteners (B) Max	Projected bearing Area Sq.cm	Avg. Weight Per Meter (Kg)	Tensile Strength (KN) (Min)	Tensile Strength (KN) (Avg)	Spares Availability
04B-1	D04B 01	6.00	2.80	4.00	1.85	5.00	7.40	10.30	0.08	0.12	3.00	3.33	A,B,C,D
05B-1	D05B 01	8.00	3.00	5.00	2.31	7.10	8.60	11.70	0.11	0.18	5.00	5.90	A,B,C,D
06B-1*	D061 01	9.525	5.72	6.35	3.28	8.20	13.50	16.80	0.28	0.40	9.00	10.70	A,B,C,D
08B-1	D083 01	12.70	7.75	8.51	4.45	11.80	17.00	20.90	0.50	0.68	18.00	21.10	A,B,C,D
10B-1	D101 01	15.875	9.65	10.16	5.08	14.70	19.60	23.70	0.67	0.91	22.40	27.45	A,B,C,D
12B-1	D102 01	19.05	11.68	12.07	5.72	16.10	22.70	27.30	0.88	1.12	29.00	32.35	A,B,C,D
16B-1	D160 01	25.40	17.02	15.88	8.27	21.00	36.10	41.50	2.07	2.59	60.00	70.60	A,B,C,D
20B-1	D200 01	31.75	19.56	19.05	10.19	26.40	43.20	49.30	2.91	3.60	95.00	109.85	A,B,C,D
24B-1	D240 01	38.10	25.40	25.40	14.6	33.40	53.40	60.00	5.49	6.85	160.00	179.00	B,C,D
28B-1	D280 01	44.45	30.99	27.94	15.90	37.00	65.10	72.50	7.26	8.56	200.00	226.00	B,C,D
32B-1	D320 01	50.80	30.99	29.21	17.81	42.20	67.40	75.30	8.05	9.49	250.00	272.80	B,C,D
40B-1	D400 01	63.50	38.10	39.37	22.89	52.90	82.60	92.60	12.61	15.53	355.00	390.50	B,C,D
48B-1	D480 01	76.20	45.72	48.26	29.24	63.80	99.10	109.10	20.40	24.45	560.00	602.00	B,C,D

* Straight Side Plates

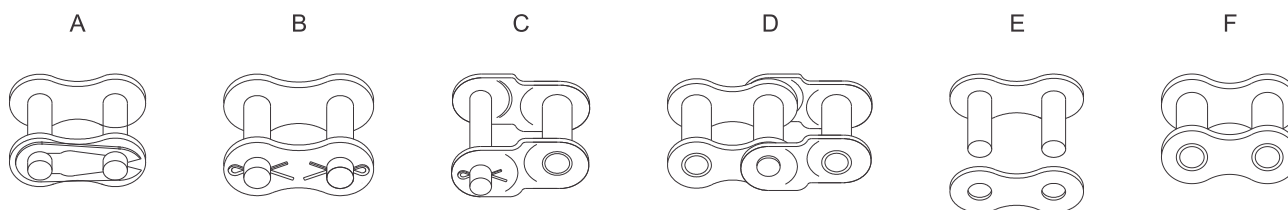

Note : Spares E & F are available for all models

STANDARD ROLLER CHAINS

EUROPEAN SERIES

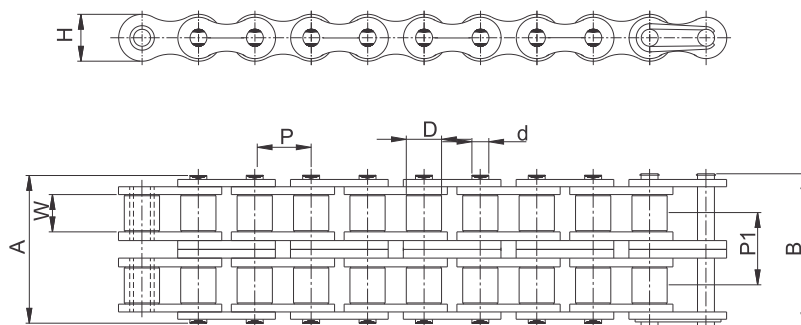

ISO 606/BS 228/DIN 8187

DOUBLE STRAND

Intl. Ref. No.	ROMBO Chain No.	Pitch (P)	Width between Inner Plates (W) (Min)	Roller Dia (D) (Max)	Bearing Pin Dia (d) (Max)	Plate Height (H) (Max)	Width Over Bearing Pin (A) (Max)	Width Over Joint Fasteners (B) (Max)	Transverse Pitch (P1)	Projected Bearing Area (Sq.cm)	Avg. Weight Per Metre (Kg)	Tensile Strength (KN) (Min)	Tensile Strength (KN) (Avg.)	Spares Availability
05B-2	D05B 02	8.00	3.00	5.00	2.31	7.10	14.30	17.40	5.64	0.22	0.32	7.80	8.55	A,B,C,D
06B-2*	D061 02	9.525	5.72	6.35	3.28	8.20	23.80	27.10	10.24	0.56	0.76	16.90	19.25	A,B,C,D
08B-2	D083 02	12.70	7.75	8.51	4.45	11.80	31.00	34.90	13.92	1.00	1.31	32.00	38.05	A,B,C,D
10B-2	D101 02	15.875	9.65	10.16	5.08	14.70	36.20	40.30	16.59	1.34	1.79	44.50	57.30	A,B,C,D
12B-2	D120 02	19.05	11.68	12.07	5.72	16.10	42.20	46.80	19.46	1.76	2.22	57.80	65.70	A,B,C,D
16B-2	D160 02	25.40	17.02	15.88	8.27	21.00	68.00	73.40	31.88	4.14	5.03	106.00	137.55	A,B,C,D
20B-2	D200 02	31.75	19.56	19.05	10.19	26.40	79.00	85.10	36.45	5.82	7.33	170.00	210.00	A,B,C,D
24B-2	D240 02	38.10	25.40	25.40	14.63	33.40	101.00	107.60	48.36	10.98	13.50	280.00	322.50	B,C,D
28B-2	D280 02	44.45	30.99	27.94	15.90	37.00	124.00	131.40	59.56	14.52	16.96	360.00	412.60	B,C,D
32B-2	D320 02	50.80	30.99	29.21	17.81	42.20	126.00	133.90	58.55	16.10	18.74	450.00	510.80	B,C,D
40B-2	D400 02	63.50	38.10	39.37	22.89	52.90	154.00	164.00	72.29	25.23	30.72	630.00	708.10	B,C,D
48B-2	D480 02	76.20	45.72	48.26	29.24	63.80	190.00	200.00	91.21	40.81	48.54	1000.00	1100.00	B,C,D

* Straight Side Plates

Note : Spares E & F are available for all models

STANDARD ROLLER CHAINS

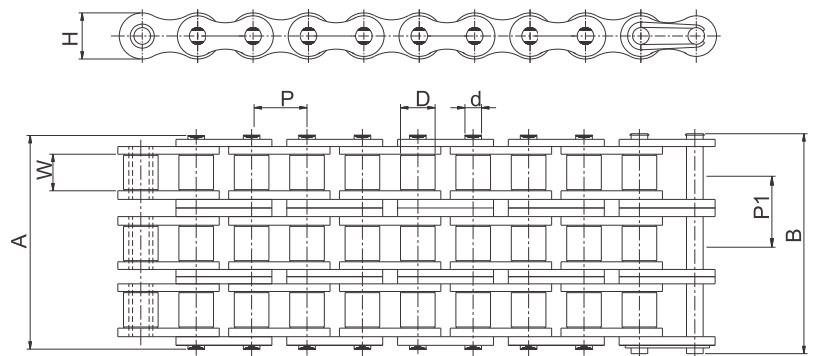

ISO 606/BS 228/DIN 8187

TRIPLE STRAND

Intl. Ref No.	ROMBO Chain No.	Pitch (P)	Width between Inner Plates (W) (Min)	Roller Dia (D) (Max)	Bearing Pin Dia (D) (Max)	Plate Height (H) (Max)	Width over Bearing Pin (A) (Max)	Width over Joint Fasteners (B) Max	Transverse Pitch (P1)	Projected bearing Area Sq.cm	Avg. Weight Per Meter (Kg)	Tensile Strength (KN) (Min)	Tensile Strength (KN) (Avg)	Spares Availability
05B-3	D05B 03	8.00	3.00	5.00	2.31	7.10	19.90	23.00	5.64	0.33	0.50	11.10	12.20	A,B,C,D
06B-3*	D061 03	9.525	5.72	6.35	3.28	8.20	34.00	37.30	10.24	0.84	1.12	24.90	27.70	A,B,C,D
08B-3*	D083 03	12.70	7.75	8.51	4.45	11.80	44.90	48.80	13.92	1.50	1.94	47.50	56.00	A,B,C,D
10B-3	D101 03	15.875	9.65	10.16	5.08	14.70	52.80	56.90	16.59	2.01	2.68	66.70	83.35	A,B,C,D
12B-3	D120 03	19.05	11.68	12.07	5.72	16.10	61.70	66.30	19.46	2.64	3.32	86.70	101.55	A,B,C,D
16B-3	D160 03	25.40	17.02	15.88	8.27	21.00	99.90	105.30	31.88	6.21	7.65	160.00	202.80	A,B,C,D
20B-3	D200 03	31.75	19.56	19.05	10.19	26.40	116.00	122.10	36.45	8.73	10.96	250.00	306.55	A,B,C,D
24B-3	D240 03	38.10	25.40	25.40	14.63	33.40	150.00	156.60	48.36	16.47	20.20	425.00	490.60	B,C,D
28B-3	D280 03	44.45	30.99	27.94	15.90	37.00	184.00	191.40	59.56	21.78	25.38	530.00	625.95	B,C,D
32B-3	D320 03	50.80	30.99	29.21	17.81	42.20	184.00	191.90	58.55	24.15	28.04	670.00	775.00	B,C,D
40B-3	D400 03	63.50	38.10	39.37	22.89	52.90	227.00	237.00	72.29	37.85	45.97	950.00	1088.90	B,C,D
40B-3	D480 03	76.20	45.72	48.26	29.24	63.80	281.00	291.00	91.21	61.22	72.67	1500.00	1648.10	B,C,D

* Straight Side Plates

Note : Spares E & F are available for all models

CERTIFICATE

Management system as per
ISO 14001 : 2004

In accordance with TÜA NORD CERT procedures, it is hereby certified that

TIDC INDIA
(UNIT OF TUBE INVESTMENT OF INDIA LIMITED)
Survey No. 264, 268/1, 268/2A, 268/2B, 269/1 & 2,
CTH Road, Ambattur, Chennai- 600 053,
Tamilnadu, India



applies a management system in line with the above standard for the following scope

Manufacture of Automotive, Industrial, Agricultural & Cam Chains, Engineering Class Chain, Fine Blanking components & Accessories

Certificate Registration No. 44 104 114274 -E3
Audit Report No. 2.5-1450/1999

Valid until 17.07.2014

Certification Body
at TÜV NORD CERT GmbH

Mumbai, 18.07.2011

This certification was conducted in accordance with the TÜA NORD CERT auditing and certification procedures and is subject to regular surveillance audits.

TÜV NORD CERT GmbH Langemarkstrasse 20 45141 Essen www.tuev-nord-cert.com



TGA-2M-07-06-00

CERTIFICATE

Management system as per
BS OHSAS 18001 : 2007

In accordance with TÜA NORD CERT procedures, it is hereby certified that

TIDC INDIA
(UNIT OF TUBE INVESTMENT OF INDIA LIMITED)
Survey No. 264, 268/1, 268/2A, 268/2B, 269/1 & 2,
CTH Road, Ambattur, Chennai- 600 053, Tamilnadu,
India



with the location
TIDC INDIA, Andhra Pradesh, India
TIDC INDIA, Uttarakhand, India

applies a management system in line with the above standard for the following scope

Manufacture of Automotive, Industrial, Agricultural & Cam Chains, Engineering Class Chain, Fine Blanking components & Accessories

Certificate Registration No. 44 116 111314
Audit Report No. 3508 2944

Valid until 2014.07.06

Certification Body
at TÜV NORD CERT GmbH

Essen, 2011.07.07

This certification was conducted in accordance with the TÜA NORD CERT auditing and certification procedures and is subject to regular surveillance audits.

TÜV NORD CERT GmbH Langemarkstrasse 20 45141 Essen www.tuev-nord-cert.com



TGA2MET-06-64

CERTIFICATE

Management system as per
DIN EN ISO 9001 : 2008

In accordance with TÜA NORD CERT procedures, it is hereby certified that

TIDC INDIA
Post Bag No.11, Ambattur,
Chennai - 600 053,
India
and other locations as per Annexure 2



applies a management system in line with the above standard for the following scope

Design, Manufacture and Supply of Standard Roller Chains, Bush Chains, Leaf Chains, Special Chains, Sprocket Roller Chains, Agricultural Chains, Conveyor Chains, Engineering Class Chains, Systems and Accessories, Manufacture and supply of Fine Blanks of Pins (Component and Sub-Assemblies)

Certificate Registration No. 44 110 011982
Audit Report No. 3517/0709

Valid until 18.07.2014

Certification Body
at TÜV NORD CERT GmbH

Essen, 18.07.2011

This certification was conducted in accordance with the TÜA NORD CERT auditing and certification procedures and is subject to regular surveillance audits.

TÜV NORD CERT GmbH Langemarkstrasse 20 45141 Essen www.tuev-nord-cert.com



TGA2MET-06-64

- ♦ All dimensions indicated are in mm.
- ♦ All information contained in this catalogue is subject to change after publication.
- ♦ While all reasonable care has been taken in compiling the information contained in this catalogue, no responsibility is accepted for printing errors.



TIDC INDIA

Unit of Tube Investments of India Ltd.

FACTORY / MARKETING HEAD OFFICE :

Post Bag No.11, Ambattur, Chennai - 600 053.
Tel. : 044 - 4223 5508 / 509 Fax : 044 - 4223 5556
Email : industrialchains@tii.murugappa.com
www.tidcindia.in

NORTH

TIDC INDIA

2nd Floor, Jeevan Deep Building,
10, Parliament Street,
New Delhi - 110 001.
Tel. : 011 - 4150 2244

SOUTH

TIDC INDIA

Post Bag No. 11, Ambattur,
Chennai - 600 053.
Tel. : 044 - 4223 5500

EAST

TIDC INDIA

Chabbildas Towers, 2nd Floor,
6A, MiddleTon Street,
Kolkatta - 700 071.
Tel. : 033 - 2281 0289

WEST

TIDC INDIA

302-A, M.P.J. Chambers,
Wakadewadi, Opp. to Centuri TVS,
Pune - 411 003.
Tel. : 020 - 2581 3170